

Wireless World

RADIO • ELECTRONICS • ELECTRO-ACOUSTICS



FEB. 1944

1/6

Vol. L No. 2

IN THIS
ISSUE :

MEASURING INDUCTANCE AND SELF-CAPACITANCE

Service Engineers

repairing domestic radio may now use

ERSIN MULTICORE SOLDER

THE SOLDER WIRE WITH 3 CORES OF NON-CORROSIVE ERSIN FLUX

Ersin Multicore — the A.I.D. approved solder wire containing three cores of active non-corrosive Ersin flux, has been adopted by the leading makers of radio and electrical appar-

atus in preference to other forms of solder because it provides speedy and efficient soldering with complete immunity from corrosive or dry joints.

Because of the economy of metals effected in using Ersin Multicore and the fact that the repair of domestic radio is now rated as an "Essential Home Civil Requirement," Service Engineers, too, can now enjoy the advantages of the finest cored solder in the world.

Stocked by the leading radio and electric factors. There may be slight delays in delivery, but insist on Multicore, and you will receive your share in turn. In case of extreme difficulty write to Multicore Solders Ltd., giving name and address of usual factor. Firms engaged upon Government Contracts are invited to write for free technical information and samples.



MULTICORE SOLDERS LTD. COMMONWEALTH HOUSE, NEW OXFORD ST. LONDON, W.C.1. Tel: CHAncery 5171/2

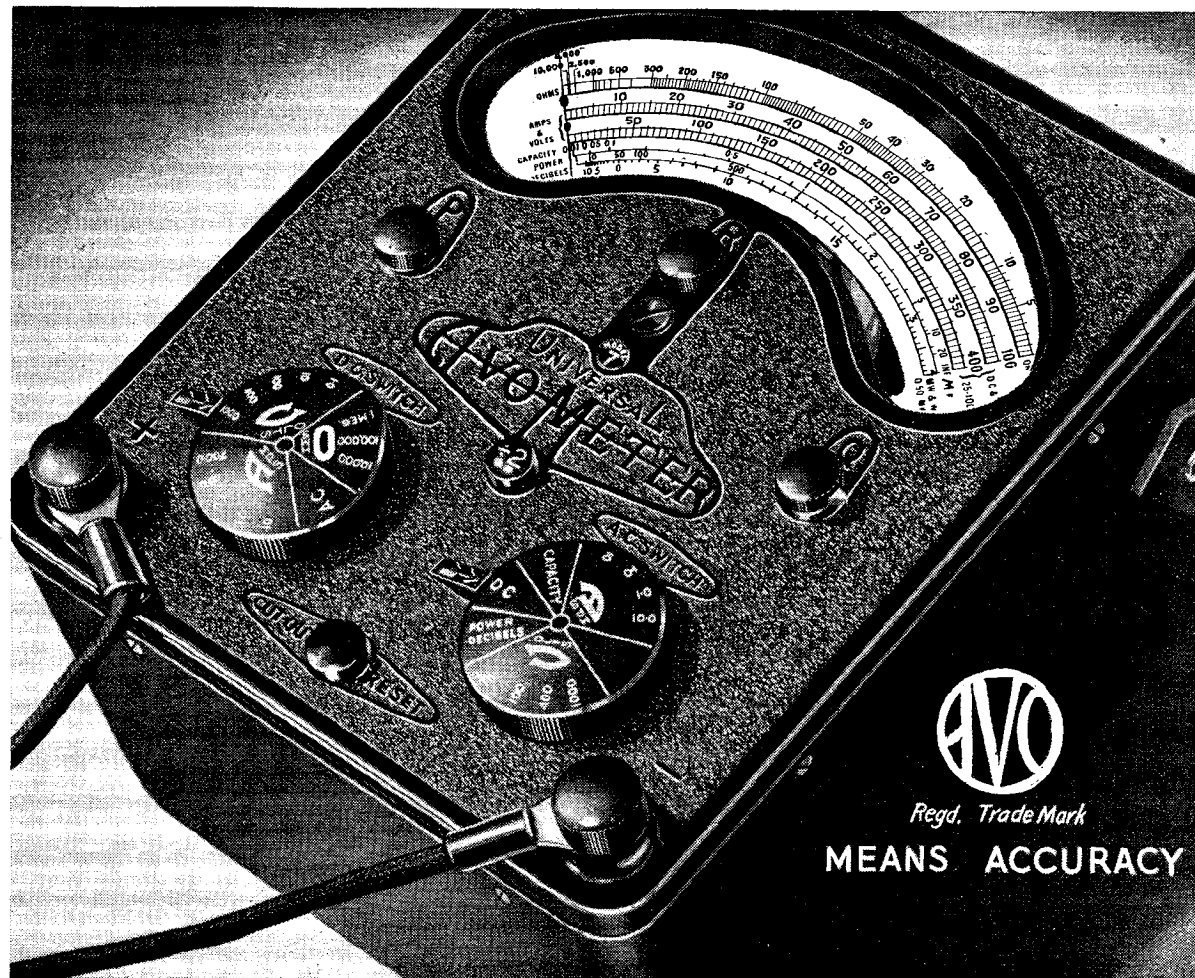

50-range Model 7
Universal AvoMeter

The Model 7 Universal AvoMeter (illustrated) is a compact combination electrical measuring instrument of B.S. 1st Grade accuracy. Its 50 ranges cover A.C. and D.C. amperes and volts, resistance, capacity, audio-frequency power output and decibels. No external shunts or series resistances. Protected by automatic cut-out against damage through overload.

Some delay in delivery of Trade Orders is inevitable, but we shall continue to do our best to fulfil your requirements as promptly as possible.

Sole Proprietors and Manufacturers:

AUTOMATIC COIL WINDER & ELECTRICAL EQUIPMENT Co., Ltd., Winder House, Douglas St., London, S.W.1

Telephone: VICTORIA 3404/7

The world-wide use of "AVO" Instruments is striking testimony to their outstanding versatility, precision and reliability. In every sphere of electrical test work—laboratory, shop or out on a job—they are appreciated for their dependable accuracy, which is often used as a standard by which other instruments are judged. There is an "AVO" Instrument for every essential electrical test.

WEBB'S RADIO

THE PRE-EMINENT SUPPLIERS OF
SPECIALISED RADIO EQUIPMENT



CRYSTAL FILTERS

Simmonds Band Pass Crystal Filter Units, 465 Kc/s. Alternative bandwidth, 1,500 Kc/s and 300 Kc/s. Both £4 10 0

MORSE KEYS

Practice type keys :—

- Metal U.S.A. Pattern 4 6
- G.P.O. Bar type on wooden base..... 8 6

Operating type keys :—

- G.P.O. Bar type, polished lacquered brasswork on wooden base..... £1 2 6

WEARITE "P" COILS

Complete tuning ranges 12 to 2,000 metres of these famous coils usually available ex stock. Three types covering all requirements (Aerial — PA1-PA7) (H.F. Transformer PHF1-PHF7) (Oscillator PO1 to PO7). Prices 2/3 and 2/6 each.

TUNING CONDENSERS

Three-gang Condensers 450 pf swing suitable for use with above coils 7 6

I.F. TRANSFORMERS

Wearite 465 Kc/s I.F. Transformers for use with above coils and condensers 7 6

S.M. DIALS

Telsen Panel Mounting, well made and with "P" Coils, I.F. Transformers and Condensers, complete and excellent tuning pack 2 0

ODDMENTS

- Microphone Cables, Single Screen..... per yard 0 9
- " " Twin " " " " " " 1 6
- Paxolin Formers, 3" x 2" diameter 1 0
- Multi-way Telephone Cable, 17, 19, 22, 32 and 34 way all per yard 1 6
- High grade Systoflex, 3 mm. 0 4
- " " " " " " " " " " 0 5
- " " " " " " " " " " 0 6

Push Back Wire, 12 yards for 1/-.
Eddystone Type 1100 Air Trimmers, 3/30 pf., 1/6.

OFFICIAL NEEDS

In addition to such components as those shown above we hold large stocks of apparatus available for official and government priority work, such as :

Metal Screening Cabinets : Black crackle steel, sizes as following Eddystone Cat. Nos. All complete with chassis front panel and hinged lid. Available for OFFICIAL REQUISITIONS.

- No. 1061 6½" wide 6" deep 7" high
- 1033 8½" wide 9½" deep 9¾" high
- 1034 17" wide 9½" deep 9¾" high

Meters.—We can often assist urgent priority needs with most of the recognised Makers' Test Equipment, Multi-range Meters, Signal Generators, Valve Testers, etc. Send 2½d. stamp for leaflet on "E44" High Precision Multi-range Meter available ex stock for contract work.

14 Soho Street, Oxford Street, London, W.1

Telephone : Gerrard 2089

We are available 9 a.m. till 6 p.m. for OFFICIAL business, but please note our SHOP HOURS—10 a.m. to 4 p.m. (Saturdays 10 a.m. to 12 noon.)

The
LOUDSPEAKER
YOU KNOW BY EAR
now making
EVERY WAR EFFORT

BRITISH Rola LIMITED
DEVIZES · LONDON · BIDEFORD
ENGLAND

RADIO CONTROL by Peter Hunt
The first publication of its kind in this country dealing with the many problems associated with the radio control of model aircraft. The author is well known for having carried out a number of successful experiments and the practical knowledge gained is fully detailed. Basic principles of the radio circuit, the design and construction of components, and circuit diagrams of working apparatus are given.
Size 8½ x 5½ ins. Price 2/- or 2/2 post free.

THE HARBOROUGH PUBLISHING CO. LTD.
ALLEN HOUSE, NEWARKE STREET, LEICESTER

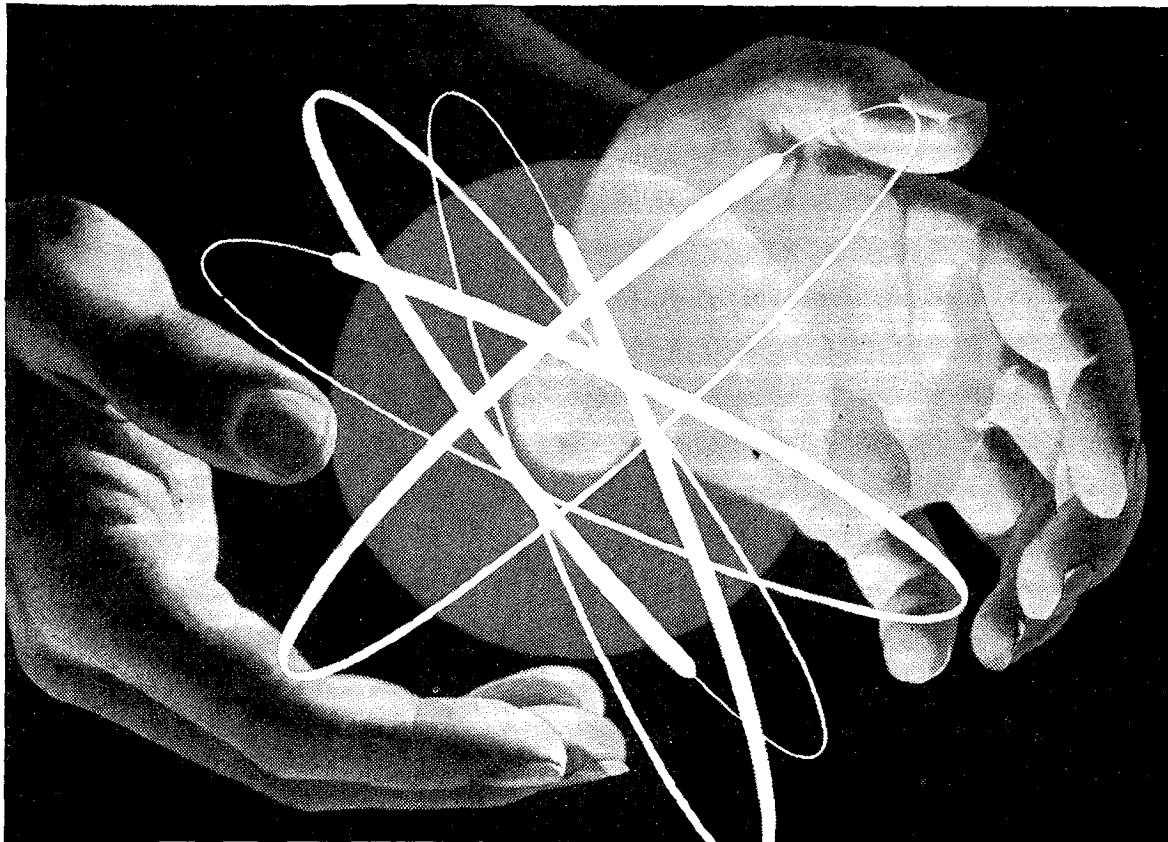

THIS IS MAGIC 1944

Through thick fog a 'plane flies safely to its base; makes a perfect landing. In a factory a wisp of smoke appears and an automatic-warning sounds the fire-alarm almost before the fire is started. A new machine records the thought-impulses of the brain. X-rays reveal the ills of human tissues, the flaws of massive metal castings—All this is the magic of electronics—the science of the electron.

Born only at the beginning of the century, this wonder-science now speeds

our industry, contributes to our safety, combats disease, probes the mysteries of the universe—And, already established as a landmark in the short history of electronics, Mazda Valves and the organisation behind them journey on towards an era of new and dazzling progress—The Electronic Era.

MAZDA valves

FOR INDUSTRIAL, MEDICAL, RADIO,
SCIENTIFIC AND DOMESTIC APPLICATIONS

ANNOUNCEMENT

WE regret that owing to pressure of Service requirements, orders for Loudspeakers and Microphones can only be accepted when accompanied by Government Contract Numbers.

A comprehensive range of Instruments is being manufactured, including Loudspeaker Units from 2½" diameter to 12" diameter; Special High Power Loudspeakers in Cabinets suitable for Tropical conditions; Hand Microphones, also Special High Sensitivity Compact Light-weight Microphones for field use; Telephone Receivers, Moving Coil Headphones, etc.

GOODMANS

INDUSTRIES LIMITED

WEMBLEY, MIDDLESEX.

LOUDSPEAKER & TELEPHONE ENGINEERS

When they have finished their vital war service



DAGENITE

AND

PERTRIX

—the dependable BATTERIES will again be available to all

FOR RADIO, CARS, MOTOR CYCLES, COMMERCIAL VEHICLES, AIRCRAFT, ETC

Sales Concessionaires: **HOLSUN BATTERIES LTD.**
137 Victoria Street, London, S.W.1.

D10b.

★ ADASTRA ★
SECTIONAL STEEL
RADIO MASTS
Send for Catalogue WD/330
POLES LTD TYBURN RD ERDINGTON
BIRMINGHAM 24

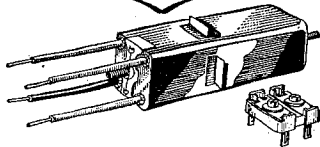

Sickles Midget Transformer and Trimmer.

OUR greatly increased manufacturing facilities in the War effort, coupled with our added production knowledge, will materially benefit you "when Victory is won." Quality has always been the dominant consideration in the design—in the choice of materials and in the method of manufacture of our products; and we look forward with confidence to the day when we shall once again continue our relationship with the Radio Industry of Great Britain with greater cordiality than ever before.

**I.F. TRANSFORMERS
AERIAL AND OSCILLATOR COILS
TRIMMER AND PADDER CONDENSERS
COIL FORMS, etc.**



**The F. W. SICKLES Co.
CHICOPEE, MASS., U.S.A.**

RAYTHEON - PROGRESS -

OVER 12,000 highly skilled Raytheon employees are producing for the military... when we again return to peacetime pursuit of normal business, the Raytheon dealers and servicemen will have the additional advantage of all of Raytheon's wartime engineering development and production of electronic tubes for the enormous number of new applications.

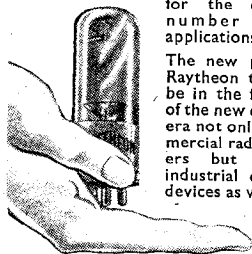

The new peacetime Raytheon tubes will be in the front line of the new electronic era not only in commercial radio receivers but the new industrial electronic devices as well.

**WORLD'S LARGEST
EXCLUSIVE
TUBE MANUFACTURERS**



**RAYTHEON
PRODUCTION CORPORATION
NEWTON, MASS., U.S.A.**

P. R. MALLORY & CO. Inc.

MALLORY VIBRATORS

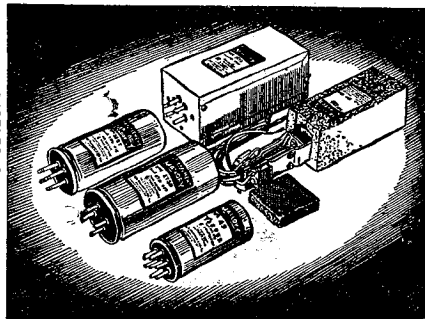

IDEAS WILL POP FOR YOU

IN the crucible that is war production, ideas pop into reality in bewildering numbers. Co-operative progress in techniques in chemical, metallurgical and electrical applications of materials, has contributed astounding gains to man's control over Nature's resources. Comparatively few can have more than a vague notion of industrial accomplishment for the war effort. But the discoveries that have mechanised warfare and conquered the air, that have developed transportation and supplies to marvellous wartime results, represent ideas that will pop into an amazing variety of commercial contributions to post-war living standards.

**P. R. MALLORY & CO. INC.
INDIANAPOLIS, INDIANA,
U.S.A.**

Radio and Electronics Division

**ALSO
"MYKROY" CERAMIC INSULATING MATERIALS
"IDEAL" RECHARGEABLE CELLS AND CHARGERS
GENERAL ELECTRONIC VACUUM CONDENSERS**

FOR THE FUTURE

These Manufacturers will help solve your post-war problems. Register your name now for full details which will be sent you when supply conditions again permit.

FRANK HEAVER

LIMITED

**Kingsley Road, BIDEFORD,
N. Devon**



VICTORY PRODUCTION

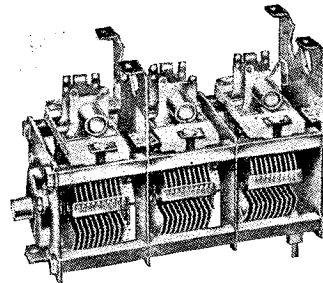

WHEN the mission of complete victory is accomplished, General Instrument will help "Win the Peace" by making the best use of still greater knowledge and experience in the manufacture of variable condensers and drives.

**THE GENERAL INSTRUMENT
CORPORATION
ELIZABETH, N.J., U.S.A.**

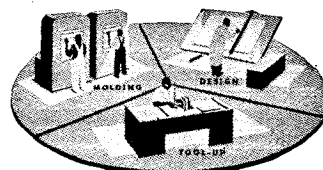

WHEN you think of plastic mouldings for post-war products we suggest you consult the Kurz-Kasch "Plastic Round Table"—a group of specialists in design, materials, tool-up and moulding. Kurz-Kasch can give you complete service under one roof, one responsibility.



KURZ-KASCH INC.
Moulders of Plastics,
**DAYTON - OHIO
U.S.A.**



The Pick of the Pack . .

A selection from the comprehensive range of Toggle Switches now produced by 'Diamond H.' Full details of these and other types can be provided on application.

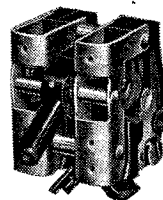

5 TDPI 4A 250 V D.P.

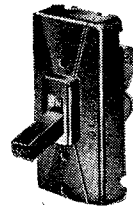

2 T 10A 250 V D.P. Panel mounting, also S.P. 2-way and momentary contact

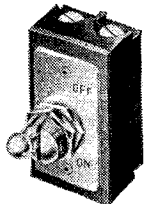

4 DP 10A 250 V D.P. 1-hole fixing

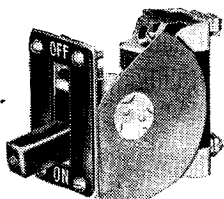

1 SP 30A 250 V S.P.

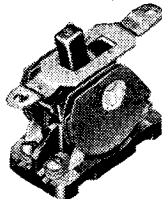

2 DP 30A 250 V D.P. (also in S.P. 2-way)

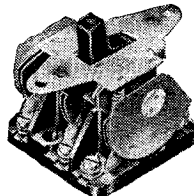

3 TP 30A 250 V or 20A 600 V Triple Pole

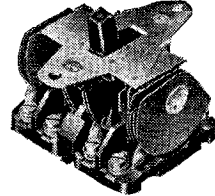

2 DPDT 30A 250 V D.P. 2 circuit (no "off" position) also in 4-pole "on" and "off" type

DIAMOND H SWITCHES

Famous for Fifty Years

'DIAMOND H' SWITCHES LTD., GUNNSBURY AVENUE, CHISWICK, W.4

M.R. SUPPLIES

Immediate delivery from stock of the following brand new **RADIO, ELECTRICAL and INDUSTRIAL EQUIPMENT**. All goods offered are of our usual highly dependable quality. All prices nett cash.

ELECTRODE WIRE JOINTERS ("Fuzit" by S.T.C.). A new and important development for the Electrical Industry. We have first supplies now available. Dispenses entirely with soldering jointed wires. Merely twist ends together—copper-copper, copper-resistance or resistance-resistance—place in jaws of tool and press and release trigger—job done, with many important advantages over the old method. Suitable for all SWG from 60 to 30. (Other models shortly available.) Complete with Portable Transformer (230/250v.), Jointing Tool and Leads, ready for use, £25 nett. Packing/carriage, 3/6.

TOGGLE PRESSES (by S.T.C.). Senior and new Minor models here in stock. Double-acting, precise tool, suitable for all small pressing operations in many trades. Senior, pressure 1½ tons, weight 150 lb., £30 nett. Minor, pressure ½ ton, weight 80 lb., £23 nett. Prices ex this address.

ROTHERMEL-BRUSH PIEZO-CRYSTAL MICROPHONES. Exceptional new offer of 500 only. Neatly housed in black bakelite, 2½ in. dia. and 2½ long, with plated mounting boss tapped standard ¼ in. (26). Fine level response and high output, suitable for all microphones uses and fully recommended by us as piezo-crystal specialists. With about 6ft. screened lead attached, only 42/-. This is undoubtedly the greatest opportunity for a good crystal microphone we have presented, now or pre-war. Suitable Floor Stands, all chromium, collapsible, portable, ext. to 6ft. 6in., with "easy-mount" adaptor, 45/6.

MINIATURE P.M. M/COIL MICROPHONE/SPEAKER UNITS (Goodman). Only 3in. dia., fitted weighty alnico magnet. Imp. 12-ohms. For use either as speaker or microphone and therefore ideal for intercom. systems, 30/-.

A.C. MAINS BELLS (Siemens). Operating direct from 200/250 v. A.C. mains. Well made on bakelite base, 3in. dia., with plated gong and adjustable note, 5/6. Suited for office, factory, laboratory, etc.

LONDEX RELAYS. 200/250 v. A.C. 2-watt coil, with triple-pole change-over 6-amp. high-tension switching, 42/6. Also same make, with 6-volt D.C. coil and breaking 2-pole (up to 3 amps. at 250 v.) when coil is energised. Miniature model, approx. 2in. by 1½ in. by ½ in. Tropical spec. and high insulation, 7/6. (Can also be used as first-rate buzzer).

LABORATORY SWITCHES on mahogany base, 4in. dia. Switch arm and six terminals (acquired brass) above and 2-pole change over, self-cleaning, low capacity switch below. Instrument finish, ex Govt., new, 10/6.

SLIDING RESISTANCES. 100 watts, fully enclosed housing, 6½ in. long, with bushed cable entries. Following range: 50 ohms 1.4 amp., 17½ ohms 0.7 amp. and 400 ohms 0.5 amp. Any one, 25/-.

ERICSSON HEADPHONES. New, in makers' boxes, with headbands, 2,000 ohms, 25/- pair. Also same make, second-hand, 2,000 ohms, 3/9 each single phone.

TRANSFORMER BOBBINS. Solving the re-wind problem. Standard for many sets, including Marconi, Pye, Lissen, etc. Prim. tapped 200/250 v., Secs. 350/0/350 75 m.a., 4 v. 3 a., and 4 v. 4 a., core opening 1½ sq. by 1½ through, 18/6.

THERMO-COUPLE AMMETERS (M/Coil) by Weston, Ferranti, Turner, etc., housed in black bakelite, with 2½ in. sq. flange, flush panel, requiring 2½ in. mounting hole. Reading 0/2½ amps. any frequency A.C. or D.C. (Despatched del. 1½ to 3 ma. D.C.), 37/6. Ex Govt., excellent condition.

Please include sufficient for packing/postage; excess refunded. Staff shortage—no C.O.D. or lists.

M.R. SUPPLIES, 68, New Oxford Street, London, W.O.1.
(Telephone : MUSEum 2958)

When clothes aren't a matter of coupons and oranges a question of age!

WODEN AMPLIFYING EQUIPMENT

will be found in many places where sound is broadcast. But it is not all over "bar the shouting" yet . . . and meanwhile "Woden supplies are for priority only, for the Fighting Services and for War Workers.

WODEN

TRANSFORMER CO. LTD.

Telephone : Wolverhampton 22829
Thornley Street, Wolverhampton

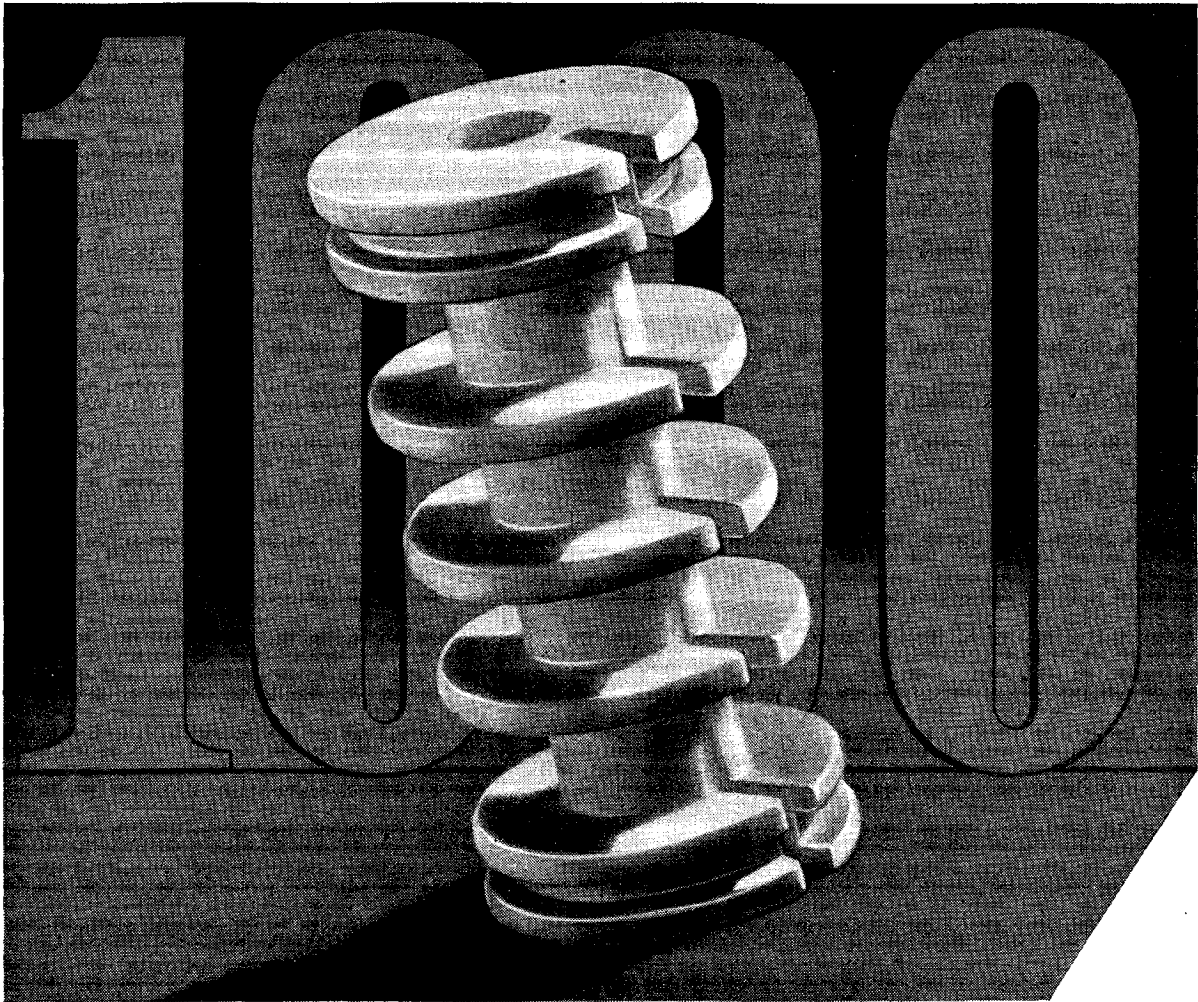

one in a thousand

Ten years ago we introduced the first British-made low-loss ceramic. To-day the range of **Frequentite** components covers more than a thousand pieces of every shape and size.

With such a store of manufacturing experience we are able to offer advice backed by practical knowledge on your insulation problem. Please consult us before you finalize your design.



STEATITE & PORCELAIN PRODUCTS LIMITED

Head Office: Stourport-on-Severn, Worcs.

Telephone: Stourport 111

Telegrams: Steatoin, Stourport

S.P.24

Unaffected by heat

How HY-MEG overcomes Impregnation Problems

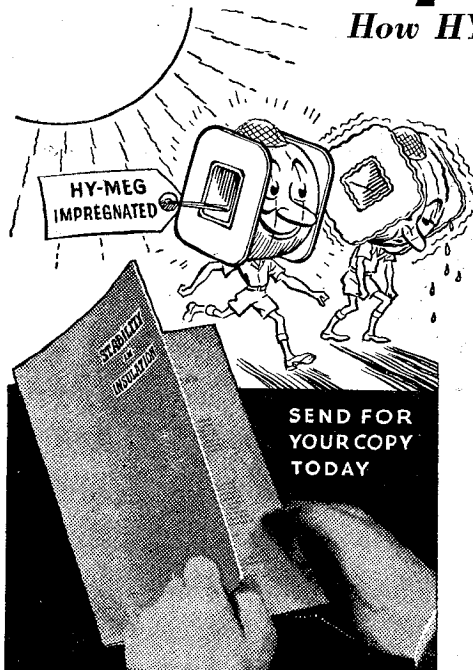

Overheating, whether due to protracted working or to tropical temperatures, can play havoc with ordinary varnish impregnations—but not with HY-MEG.

For there is nothing ordinary about HY-MEG as you can readily understand by reading the recently published booklet, "STABILITY IN INSULATION." When you learn also that HY-MEG needs less stoving time, gives mechanical rigidity, improves the electrical properties of windings, resists moisture, oils, acids and alkalis, (besides being unaffected by heat), then the reasons why it is being more and more widely used by leading impregnators become apparent. HY-MEG, the successful outcome of the call for positive stability, has banished such faults as softening of wire enamel, breaking of wires, etc. More detailed information on these important matters is given in the booklet. Please apply for your copy on Business Heading or Card, enclosing 2d. to comply with the Control of Paper (No. 48) Order, 1942.

HY-MEG IMPREGNATING VARNISH

V. 6934. Made specially for enamelled wire-windings; but is equally suitable for Rayon and Glass-covered wire.

CONSULT
OUR 'BRAINS TRUST'
The HY-MEG 'Brains Trust' is always in session, ready to deal with questions relating to insulation. Any special problem put to it brings helpful response.

INSULATE WITH

HY-MEG

TO BE SURE

LEWIS BERGER & SONS LTD., (Established 1760) LONDON, E.9 'Phone: AMHerst 3321

MANUFACTURERS OF INSULATING VARNISHES AND ENAMELS

Lister Electronic Products Co.

CLEVELAND,

OHIO

SPECIALISTS IN UHF EQUIPMENT

MULTI-CHANNEL
FREQUENCY MODULATED KEYING LINKS

MULTIPLE CRYSTAL HOLDERS
FOR UP TO 100 CRYSTALS

TEST GEAR:—HF AND UHF OSCILLATORS,
CRYSTAL CONTROLLED MULTIVIBRATORS

AUTOMATIC ALARM SYSTEMS

INDUCTION HEATING FURNACES

PRIORITIES ONLY

For details write to:—

Electronic Engineering Services, Ltd.

SOLE BRITISH DISTRIBUTORS



24 STANLEY ROAD, HEATON MOOR, STOCKPORT

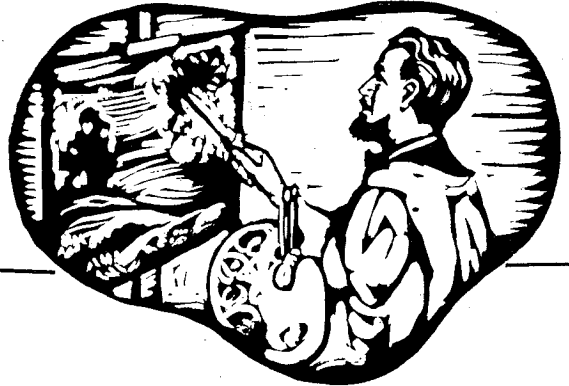

The 'Master Touch'

In Radio, as in painting, technique is all important. New knowledge gained during the war period will bring you a new and better post war

Masteradio

Planning today for tomorrow

MASTERADIO LTD., WATFORD, HERTS

MANSBRIDGE TYPE METAL-CASED CONDENSERS —350 v. WORKING—

10 mfd.	Size 4½ × 3 × 2½ in.	9/6
4 mfd.	" 4 × 1½ × 2 in.	6/6
2 mfd.	" 4 × 1½ × 2 in.	4/6
2 mfd.	" 4 × 1 × 1½ in.	2/6
2 mfd.	" 2½ × 1 × 1½ in.	2/6
.02 mfd.	Size 4½ × ½ × 1½ in.	1/6
.2 + .2 mfd.	Size 2½ × ½ × 2 in.	2/6

500 v. WORKING

2 mfd. . . 9/6
Size 4½ × 3 × 2½ in.

Also 250 mfd., 25 v., in Bakelite case, 2/6.

MANUFACTURER'S STOCK:

- HEAVY DUTY MAINS TRANSFORMERS.** Input 200-250 v. A.C., 350-0-350 v. 120 m.a., 33/6
4 v. 2 a., 4 v. 3 a., 6.3 v. 4 a. Weight 11 lbs.
- HEAVY DUTY CHOKES,** 140 ohm., 150 m.a. 25/-
- SLIGHTLY USED VALVES—PERFECT.**—X65 Osram-Marconi Triode Hexode, 10/- . MHL D 6.3 v. Double-diode-triode, 7/6. Battery Triode H.F. Detector, 2 v., 4/6. VW48 Battery S.G., 2 v., 8/- . VT51 Battery Pentode, 2 v. 5-pin, 7/6. VR57 Frequency Changer, 10/- . P220 Battery Power, 2 v. 4-pin, 5/- . VT55 D.D. Triode, 6.5 v., 2 amp., 7/- . Mercury Vapour Rectifiers, 8/- . Battery Power, 2 v., 5/- .

PLATINUM CONTACTS
Double spring, mounted on ebonite ... 1/6



EXTENSION SPEAKERS.

Brand new, first-class P.M. speakers in beautifully polished cabinets ... 52/6
In Rexine covered cabinets ... 50/-

LOUDSPEAKERS

ROLA 10in. P.M. Speakers, 35/- . CELESTION 8in., with transformer, 29/6.

GOODMANS P.M. SPEAKERS, without transformers: 5in., 21/-; 8in., 30/-; 10in., 47/6. Post and packing, 1/6 each extra.

ON-OFF TOGGLE SWITCHES ... 2/9

PENTODE OUTPUT TRANSFORMERS, suitable for small speakers, 1½ × 1½ × 1½, 7/- .

COSSOR 0.025 CONDENSERS, 8,000 v., 7/6
METAL-CASED CONDENSERS, 0.03 mfd., 500 v., 1/3.

T.C.C. TUBULAR CONDENSERS, 0.1 mfd., 6,000 v. D.C. test, 8/9; 0.04 mfd., 350 v., 2/-; 0.22 mfd., 350 v., 1/-; 2 mfd., 350 v., 3/6.

T.C.C. CONDENSERS in metal cases, special offer, much reduced to clear, 4 × 4 mfd., 70 v. working, 2/6 each.

CONDENSERS, tubular wire end, made by Plessey, 25 mfd., 25 v. working, 50 mfd., 12 v. working, 1/9 each.

SCANNING AND DEFLECTOR COILS

Ex-television receivers, assembled complete in metal frame, as illustrated, 7/6

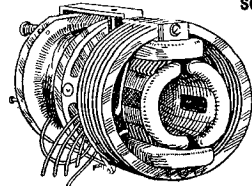

For RELAYS, etc., see last month's advertisement.

EX-GOVT. PLUGS AND JACKS

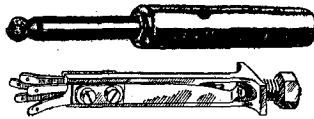

As previously advertised ... 5/9

METAL SCREENED ANODE VALVE-CAPS, with short screened lead, ... 9d.

RED BAKELITE ANODE CAPS ... 1/-

HEAVY METAL SCREENED CABLE. Single, 1/- . Twin, 1/6 per yd.

TRIMMERS. Postage stamp 40 PF., 6d. Twin 40+40 PF., 1/- .

PHILIPS POTENTIOMETERS. 100,000 ohm. With switch, 4/6; without switch, 3/6.

CARBON POTENTIOMETERS. 50,000 ohm, 5/6.

ELECTRO-MAGNETIC COUNTERS

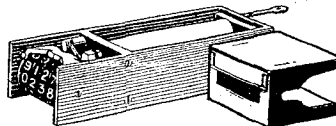

Ex-G.P.O., every one perfect, electro-magnetic, 500 ohm coil, counting to 9,999, operated from 25 v.-50 v. D.C., many industrial and domestic applications ... 6/-

VIBRATOR UNITS

—Synchronous—

Brand new American synchronous self-rectifying vibrator units, 12 v. input, 230 v. output, 65 m.a., fitted with 7-pin American base, ... 16/-



LONDON CENTRAL RADIO

Miscellaneous Offers:

H.M.V. TRANSFORMERS. 5,000 v., 26 v. tapping, 12/6.

CHASSIS, 14 × 8½ × 3in., drilled for 11 valves and transformer, 6/6.

STEP-UP, STEP-DOWN TRANSFORMERS, 100-240 v., 60 w., 30/6.

2-GANG SUPERHET VARIABLE CONDENSERS, 0.0005 mfd., with trimmers 10/6.

YAXLEY TYPE WAVE-CHANGE SWITCHES, 4-way, 3-bank, with shielded oscillator section, length from stop plate approx. 5in., spindle 2in., 6/3; 5-way, 6-bank, with 3 screened sections, adaptable to many uses, length from stop plate approx. 6¼in., spindle 2in., 7/3; 3-way, 3 double banks, without shields, 2in. spindle, length 6¼in., 6/3.

YAXLEY PATTERN SWITCHES, 5-way, single bank, on-off mains switch, carrying 1 amp. at 250 v., 2in. spindle with knob, 6/-; 3-way, single bank, 1in. spindle, with knob, 3/3.

OAK SWITCHES, 2¼in. spindle, complete with knob, 4-way, 2-bank, with connecting block, 5/-; 4-way, 2-bank, 4/3.

SPEECH TRANSFORMERS, brand new, ex well-known speaker maker, ratio 30:1, a fine job, 6/9.

RELAYS. Brand new, surplus stock, electro-magnetic make and break units to operate on 1½ v. at 15 m.a.; to clear stock, 5/9 each.

MOTOR TUNING. Fine brand new 3-gang 0.0005 mfd. condenser, no trimmers, designed for motor drive, large diameter driving disc and reduction gear for slow motion manual drive, 13/6 each.

BRASS ROD. Screwed brass rod, 2 B.A., 4 B.A., and 6 B.A., 12in. lengths, useful for many purposes, 5/6 doz. lengths.

VALVE-HOLDERS, all brand new, Celestion Amphenol, Mazda and Inter. octal, 1/-.

VALVE-HOLDERS. Paxolin, 7- and 9-pin, 7d. each, 6/- doz.

DROPPING RESISTANCES. To replace 2- and 3-way line cords, with diagram showing connections, 0.3 amp., in strong metal case, 13/- each; without case, 10/- each.

VITREOUS ENAMELLED RESISTANCES, 10,000 ohm, 10 w., 3/6.

ELECTRIC RAZOR RESISTANCES, universal input, in strong metal case, 10/- each.

REACTION CONDENSERS. Fine quality job, 0.00003 mfd., to clear at 2/3 each.

TUBULARS. Wire-end tubular condensers, 0.1 and 0.01 mfd., 400 v. working, 1/-.

VALVE-HOLDERS. Side contact, 8-pin type, in bakelite, 1/9 each; anode bakelite valve caps, 8d.; anode valve caps with screened lead, 1/3.

DIAL LAMPS. Philips' screw type dial lamps for dial illumination, 15 watt, 1/9 each.

SPEECH COIL RIBBON WIRE, enamelled copper, gauge approx. 20 thou. by 5½ thou., 3/3 per lb. reel; also 23 s.w.g. d.c.c. wire, 100 yd. coils, 5/6.

FLEXIBLE DRIVES. Ideal for remote control in radiograms, etc., approx. 3ft. length, 4/3.

VALVES. EA50, Mullards, to clear, 10/6 each.

PUSH BUTTON UNITS. Permeability iron-cored coil units, 6 spring loaded switches, 16/- each; 8-switch unit (no coils), 4/6 each; 12-switch unit (no coils or switches), 2/6 each.

RESISTANCES. Assorted wire-end resistances by best makers, ideal for servicemen and experimenters, to clear, 3/6 doz.; 13/3 for 50; 23/6 for 100.

CERAMIC VALVE-HOLDERS, brand new, low loss, 7 pin, 1/5 each.

CONDENSERS. First-class 0.1 mfd., oil-filled, 5,000 v. working, only 11/6 each.

TWIN SCREENED PICK-UP LEADS, fitted 2 plugs, 8ft. 6in. long, 2/9.

LONDON CENTRAL RADIO STORES

23, LISLE ST.,

LONDON, W.C.2

Phone: GERard 2969.

The story behind the scale

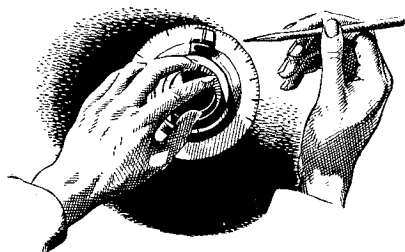

★ How precise itself must be the means of measuring precision! In Radio the means implies Marconi instruments, of many types specifically designed to measure precise performance in communication equipments.

The last graduation on a calibrated dial is the finishing touch to a Marconi instrument; a meticulous operation, but not more so than the many preceding it. For behind this work—back to the very birth of wireless communication—is a tradition of skill and workmanship.

The complete answers to questions of measurement are found entirely within the Marconi organisation. That is why such a diversity of instruments is produced to meet many and increasing requirements. Our activities are centred around this specialised work—perhaps already we have anticipated *your* particular problem.

MARCONI Instruments Ltd

ELECTRA HOUSE, VICTORIA EMBANKMENT, LONDON, W.C.2

RAYMART VALVEHOLDERS

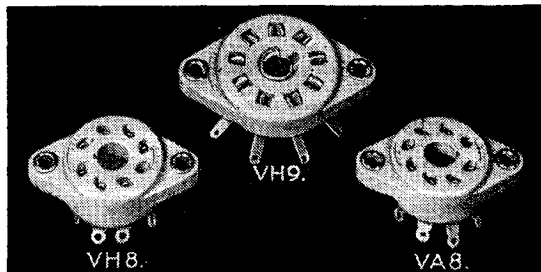

These three latest types of Raymart valveholders, have ribs between each contact to increase the effective distance between, and also to prevent tracking. Their Pierced solder tag connections protrude through base of Ceramic. Other features are standard with other types. See details below.

Bases. These are of the famous RMX low-loss Ceramic.

Contacts. Resilient bronze alloy, sterling silver-plated, minimum contact resistance.

Fixing. Floating nickel-plated eyelet (4BA clearance) fitted in strengthening boss in Ceramic. Metal floating bushes prevent cracking of Ceramic plates.

Soldering. Pierced solder tag at end of sockets. Types manufactured: English 4- and 5-pin, American 4.5, and large 7-pin.

NOTE: English types VH4 and VH5 are made in three different types with two different fixing centres.

Enquiries invited from Government Departments, Traders and Servicemen. We have a civilian allocation.

TYPE VH8
Mazda Octal
1/3 each.

TYPE VA8
International Octal
1/3 each.

TYPE VH9
British "E" type
1/9 each.

RAYMART

48, HOLLOWAY HEAD, BIRMINGHAM, 1
Telephone: Midland 3254.

Listen to this...



Language of the Drums—still one of the wonders of Equatorial Africa. News travels incredible distances by instant relay, village to village...

AND ON THE FACTORY FRONT

trix
TRIX

Quality SOUND Equipment

AVAILABLE FOR PRIORITY ORDERS. SEND FOR DETAILS

THE TRIX ELECTRICAL CO. LTD., 65, BOLSOVER STREET, LONDON, W. 1

Phone: EUSTON 5471/2

Gramic 6 Cones; TRIXADIO, WESDO, LONDON.



the amateur is still in radio...

All through the development of radio communications you'll find the mark of the radio amateur. His desire to accomplish the seemingly impossible and the rough treatment he gave his "ham rig" helped create and develop better radio technique. Thus the radio amateur is directly responsible for much of the superior radio and electronic equipment being used by the military services today. Eimac valves, created and developed in the great amateur testing ground are a good example. They had to possess superior performance capabilities in order to become first choice of the leading radio amateurs.

Their ability to withstand momentary overloads of as much as 600% and their unconditional guarantee against premature failures due to gas released internally are two potent reasons why they are today first choice of the leading electronic engineers throughout the world.

Today the radio amateur is off the air as an amateur but he's still in radio as a professional. And wherever he is... in the army, navy and marine corps... in the great electronic laboratories and factories... he's still using Eimac valves.

Follow the leaders to

Eimac
VALVES

EITEL-McCULLOUGH, Inc., SAN BRUNO, CALIF.

Plants at: Salt Lake City, Utah and San Bruno, California

Export Agents: FRAZAR & HANSEN, 101 Clay Street, San Francisco, California, U. S. A.

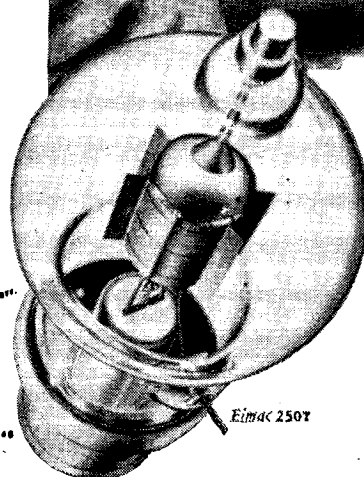



SILVERED MICA CONDENSERS

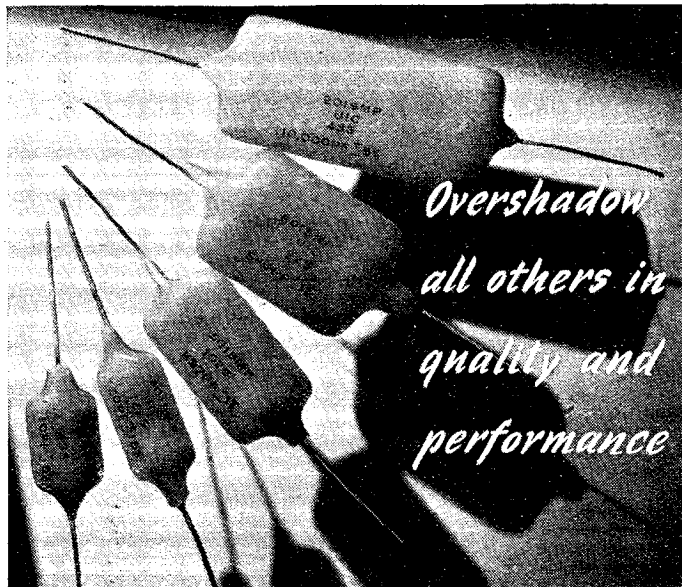

*Overshadow
all others in
quality and
performance*

Incessant progress in methods of manufacture and research linked with the most thorough mechanical and electrical inspection, are reasons for the outstanding superiority of U.I.C. Silvered Mica Condensers. Available in all standardized sizes. Suitable for tropical and arctic conditions. Type approved.

UNITED INSULATOR CO. LTD
12-22, LAYSTALL STREET, LONDON, E.C.1

Tel: TERminus 7383 (5 lines)
Grams: Calanel, Smith, London

THE PIONEERS OF LOW LOSS CERAMIC

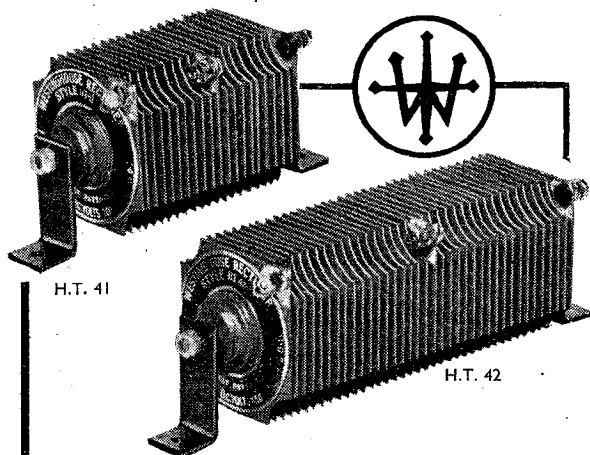

H.T. 41

H.T. 42

H.T. UNITS IN 'WESTALITE'

Two new H.T. units in 'Westalite' selenium-compound are now available for priority orders. Both types are suitable for a maximum output of 100mA and may be used either half-wave or voltage doubler. Maximum output volts H.T. 41: 200 and H.T. 42: 475 at 100mA.



METAL RECTIFIERS

WESTINGHOUSE BRAKE & SIGNAL CO., LTD.,
Pew Hill House, Chippenham, Wilts.

HIVAC
THE SCIENTIFIC
VALVE
BRITISH MADE

Specialists in
**MIDGET
VALVES**

HIVAC LIMITED
Greenhill Crescent,
Harrow on the Hill, Middx.

Telephone: Harrow 0895

◆ LINAGLOW LIMITED ◆

ANNOUNCE the purchase of a well-known British Manufacturer's pre-war stock of **RADIO COMPONENTS, CABINETS, etc.**

All in perfect condition, brand new, finest quality. Many items considerably below pre-war prices. Quantities are limited—DO NOT MISS THIS OPPORTUNITY.

MULLARD & MAZDA CATHODE RAY TUBES

7 in. **£3 10 0** 9 in. **£4 18 0**

HOLDER, for above, complete with mounting base, scanning and focussing unit with coil Brand new **47/6**

HIGH VOLTAGE TRANSFORMER, for above, 200/250 v., 4,000 v., 2 v., 2 amp. **47/6**

Line scanning output transformer..... **12/6**

1 T.C.C. 4,000 v.w. Condensers for above, Brand new **8/6**

RECTIFIERS FOR ABOVE, UU4 at 11/-; U21 at 18/3 Plywood frame and rubber mount for Cathode Ray Tube, also suitable for loudspeaker baffle, 7in. hole **7/6**

VOLTAGE DROPPING AND LINE CORD REPLACEMENT RESISTORS

3 amp. 600 ohm **LINE CORD RESISTOR** chassis mounting, with adjustable slider, 6/6. As above, 2 amp., 5/9.

SPECIAL HEAVY DUTY RESISTORS, 5-watt for bias, etc., all values from 25 to 2,000 ohm, with copper clips, 1/9 each. Similar to above but 10-watt, 2/3.

50-ohm centre-tapped Resistor, tapped at 25 ohm, for pilot lamps, 2/-.

SPECIAL MULTI-LINE CORD RESISTOR, 5 tappings 50 ohm, 1 tapping 750 ohm, with slider, 2 amp., 8/6. 950 ohm, 2 amp., Chassis mounting, heavy duty on porcelain former, 2 adjustable tappings, 8/6 each.

UNIVERSAL RESISTOR, Suitable for practically every type of American and British AC/DC Receiver, supplied in safety metal cage with asbestos lining. Specification: 750 ohms, 3 amp., with four sliders for adjustable tappings, 12/6.

UNIVERSAL RAZOR RESISTANCE, Suitable for practically every type of electric Razor, drops voltage from 200/250 to 100/110 v. Supplied in safety metal cage with asbestos lining. Specification: 1,500 ohms with adjustable slider, 10/6.

LINE CORDS, 3-way heavy duty, 3 amp., 360 ohms, 13/6; 480 ohms, 17/6; 600 ohms, 21/-.

3 1/2 in. **GOODMAN P.M. LOUSPEAKER**, Extra heavy magnet for Midgets and communication sets, 30/-.

VOLUME CONTROLS, 1,000, 5,000, 10,000, 20,000, 25,000, 50,000, 100,000-ohm; 1/2, 1/4, 1 and 2 megohm, without switch, 4/9 each. As above, with switch, 6/9.

L.F. SMOOTHING CHOKES, Finest quality, 20, 40 and 60 henries 150 m.a., 16/9 each.

SWITCHES, DDDT panel mounting, P.O. type, 2/6. D.P. 4-point push-pull, 9d.

VALVE HOLDERS—AMPHENOL TYPE, International or Mazda Octal, chassis mounting, 1/-.

RADIO CHASSIS

No. 1. 18 gauge steel, cellulosed grey, fitted 4 octal valve holders, grommets, with 20 colour coded resistors. Dimensions: 11 x 7 1/2 **17/6**

No. 2. 18 gauge steel, cellulosed grey, fitted mains socket and three 4-pin valve holders, grommets drilled ready to take transformers, chokes, etc. Dimensions: 14 x 10 1/2 x 1 1/2 **18/6**

No. 3. 8-valve 18-gauge steel, cellulosed grey, fitted with octal valve holders, 7 I.F. and aerial transformer cans fitted with odd coils and trimmers, volume control, aerial and earth sockets, mains plug and socket, 24 assorted colour coded resistors, 24 T.C.C. condensers, various trimmers. Dimensions: 8 x 12 x 1 1/2 **30/-**

◆ **CALLERS to Show Rooms, 61 HIGHGATE HIGH ST., N.6.**
Phone: MOUview 9432

HUMDINGERS, 25,000 and 50,000 ohms, 6d. each.

SCREENED INTERCALATED FLEXIBLE MICROPHONE CABLE, Single, Special Offer, 9d. per yd. Pre-war Super Quality, 1/3 per yd. Twin, 1/3 per yd.

.003 VARIABLE CONDENSERS WITH TRIMMERS, 3-gang, completely screened. Ideal for short-wave work, 3-hole chassis mounting. Bargain, 4/6.

SERVICE KITS

SKA. 1 8-mfd. 400/500 v. Electrolytic; 1 200-mfd. x 12 v. Bias Electrolytic; 6 assorted Silver Mica Condensers; 6 assorted Resistors; 6 assorted Trimmers. **12/6** per kit

SKB. 1 16 x 8-mfd. 400 v. Electrolytic; 1 25-mfd. x 25 v. Bias Electrolytic; 6 assorted Silver Mica Condensers; 6 assorted Resistors; 6 assorted Trimmers; 6 assorted Tubular Paper Condensers. **15/9** per kit

SKC. 1 16 x 8-mfd. 400 v. Electrolytic; 1 8-mfd. 400/500 v. Electrolytic; 1 200-mfd. x 12 v. Bias Electrolytic; 1 25-mfd. x 25 v. Bias; 6 assorted Silver Mica Condensers; 6 assorted Resistors; 6 assorted Trimmers; 6 assorted Tubular Paper Condensers; 1 4-point Push-Pull Radio Switch; 1 Tone Control; 1 roll Insulating Tape. **32/6** per kit

SKD. 2 8-mfd. 400/500 v. Electrolytics; 2 16 x 8-mfd. 400 v. Electrolytics; 1 200-mfd. x 12 v. Bias; 1 25-mfd. x 12 v. Bias; 1 25-mfd. x 25 v. Bias; 1 24-mfd. x 250 v.; 12 assorted Silver Mica Condensers; 12 assorted Trimmers; 12 assorted Resistors; 12 assorted Tubular Paper Condensers; 3 assorted Volume and Tone Controls; 2 4-point Push-Pull Radio Switches; 1 roll Insulating Tape. **£3 7 6** per kit

SKE. 3 8-mfd. 400/500 v. Electrolytics; 2 16 x 8-mfd. 400 v.; 1 40-mfd. x 250 v. Block; 1 24-mfd. x 250 v. Block; 1 16 x 16 mfd. 400 v.; 2 32-mfd. x 325 v.; 2 25-mfd. x 12 v. Bias; 2 25-mfd. x 25 v. Bias; 2 200-mfd. x 12 v. Bias; 2 1 4,000 v. T.C.C. Condensers; 50 assorted Silver Mica Condensers; 50 assorted Resistors; 50 assorted Trimmers; 50 assorted Tubular Paper Condensers; 3 assorted Volume and Tone Controls; 3 4-point Push-Pull Radio Switches; 2 rolls Insulating Tape; 1 Pentode Output Transformer; 2 Line Cord Replacement Resistors; 2 lengths 3.3-way Line Cord 360 ohms. **£8 19 6** per kit

MICROPHONES, De Luxe Piezo Crystal microphones in chromium case. Specification: 60 D.B. below .1 volt. Frequency response 30/3,000, C.P.S., 6 Gns.

As above—Standard model in bakelite case, 3 Gns.

I.F. TRANSFORMERS 465KC. Aluminium can with flying lead, 7/6.

ALUMINIUM VALVE CAPS, Special price 6d.

3-CORE MAINS LEAD with iron connector fitted, 5/-.

SCREENED MICROPHONE LEAD, fitted four Wander Plugs, 3/6.

6 ASSORTED VOLUME AND TONE CONTROLS with and without switch, 19/6.

◆ **LINAGLOW LIMITED**
HOURS OF BUSINESS 9 a.m. to 5.30 p.m.
Saturday, 9.30 a.m. to 12.30 p.m.

CABINETS

No. 1. Exceptionally well-made pre-war radio cabinets, figured and inlaid walnut, large enough for radio chassis, loudspeaker and power pack. Dimensions: 20in. x 17in. x 16in. **4 Gns.**

No. 2. As above—dimensions: 22in. x 17in. x 16in. **£4 12 6**

No. 3. **DE LUXE** Console model—specification as above. Dimensions: 38in. x 19in. x 16in. **8 Gns.**

Packing case for all above, 10/- extra.

TUBULAR STEEL FRAMES, Cadmium plated for radio chassis mounting and many other purposes, drilled ready for use—18in. high x 14in. wide—very useful for swivel frame in Radio Laboratory, 7/6 the pair.

SUPERIOR QUALITY STREAMLINE RADIO KNOBS, For 1/4 in. spindles with grub screw. 1 1/4 in., 1/9; 1 in., 1/3; 3/4 in., 9d.

TUBULAR PAPER CONDENSERS, 350-500 v., D.C. working, .0001, .0003 mfd., 4/- doz.; .001, .004, 6/- doz.; .01, 7/- doz.; .05 mfd., 9/- doz.; 1 mfd., 12/- doz.; .25, .5 mfd., 15/- doz., or assorted parcel of 50 for 27/6. Minimum orders, 1 doz. any type.

SILVER MICA CONDENSERS, Flat wire-end. Assorted values, 17/6 per 100 (not more than 5 alike).

LOUDSPEAKER TRANSFORMERS, Tapped Power Pentode Output, 75 m.a. ratios 42:1 and 55:1, 10/6. Push-Pull output tapped Primary and Secondary, 120 m.a. ratios 10:1, 5:1 and 3.5:1, 15/-; Multi-Ratio and Push-Pull transformer, ratios 30:1, 45:1, 60:1, 90:1 and P.P. class B, 75 m.a., 12/6. Heavy duty multi-ratio transformer, ratios 24:1, 41:1, 48:1, 58:1, 82:1, 116:1, 80 m.a., 15/6.

MAINS TRANSFORMERS, 200/250, 350-0-350, 4 v. 6 amp., 4 v., 3 amp., 120 m.a. or 6.3 v., 3 amp., 5 v., 2 amp., 37/6. 4 v., 4 amp., 4 v., 4 amp., 100 m.a., 30/-; 300-0-300, 4 v., 6 amp., 4 v., 2 amp., 150 m.a., 42/-; 325-0-325, 4 v., 6 amp., 4 v., 2 amp., 2 v., 1.5 amp., 150 m.a., 45/-.

AUTO TRANSFORMERS, Step up or down 110/210/220/240 v., 100-watt, 35/-; 110/240 v. 75 watt, 27/6.

LOUDSPEAKERS, P.M. 3 ohm voice coil without transformer, 5in., 21/-; 6in., 22/6; 8in., 25/6; 10in., 28/6. 10in. R.G.D. energised M.C. Speaker, 250 and 500 ohm field, 2.5 ohm speech coil, 30/-. Any of the above can be supplied with pentode output transformer, 10/6 extra. With multi-ratio, 15/- extra.

VALVES

AMERICAN TYPES AT R.O.T. CONTROLLED RETAIL PRICES FOR REPLACEMENT PURPOSES ONLY.
1H5, 12F5, 12SF5, 9/2; 1A5, 1C5, 5Y3, 6X5, 25Z6, 35Z4, 35Z5, 11/-; 6Q7, 12Q7, 12SQ7, 11/7; 6BF6, 6K7, 12J7, 35L6, 36, 42, 78, 12/10; 6A8, 6B8, 6K8, 6SA7, 12SA7, 14/-; 70L7, 83, 15/8.

Also British Valves at Manufacturers' List Prices.
HL41DD, 9/2; AC/ME, 10/6; UU4, UU6, UU7, 11/-; TDD4, 11/7; AC/VP2, CL4, EF89, KTWO1, Pen 45, SP41, SP42, VP41, 12/10; DI Diode 1in. Peanut Valve with valve holder, 13/10; ECH3, PC13, X63 X65, 14/-; AC6Pen* EL35, Pen 46* T41, U21, 18/8.

*Post Office Permit necessary.

All prices include Purchase Tax. Add 3d. per valve postage.

◆ **POST ORDERS to Dept. M.O.10, 3 HAMPSTEAD LANE, N.6. CASH WITH ORDER ONLY.**

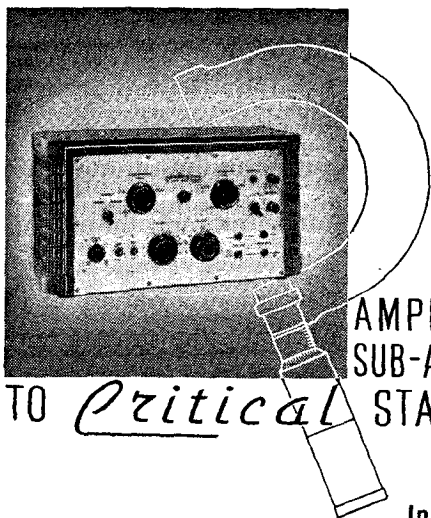

AUDIO AMPLIFIERS & SUB-ASSEMBLIES TO *Critical* STANDARDS

In addition to Standard Amplifiers the activities of Acoustical include Special Amplifiers for Industrial Applications, Microphones, Transformers, Coil Winding, Sheet Metal Work, Stampings, Switch Assemblies, etc.



WHARFEDALE

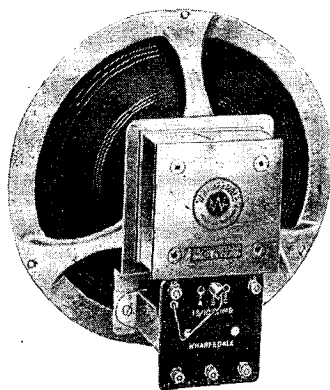

GOLDEN CHASSIS

Basically unchanged since 1935 . . . and still in the forefront to-day!

The Response Curve here shown was taken nearly 7 years ago and it has been found impossible to improve on it by any change in the Cone. Improvements to the suspension have brought the Cone Resonance down to below 75 C.P.S. Used by B.B.C., G.P.O., etc.

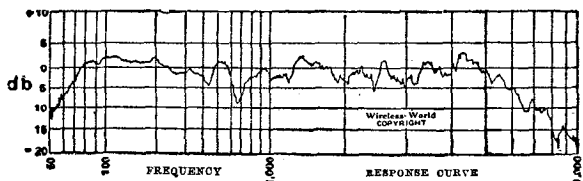

PRICE 70/- (without Transformer). PRIORITY ORDERS ONLY
WHARFEDALE WIRELESS WORKS
 HUTCHINSON LANE, BRIGHOUSE, YORKS.

RIGHT: One of the large fleet of Daylight Mobile Cinemas covering the country on behalf of many Official campaigns.
 BELOW: Part of the interior of a Daylight Mobile Cinema showing the very latest 16 mm. Sound Film Projector.

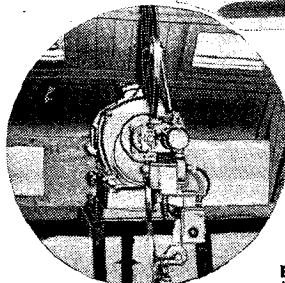

"We're taking the pictures to the family to-day!"

Every day of every week we are taking the pictures to the family . . . in the open air . . . in daylight . . . giving perfect projection! Naturally, this service is primarily used nowadays for the exhibition of Government films, but if you would like to know a'out the potentialities of the Mobile Cinema as it can affect your business we'll gladly send you full details.

BRITISH FILMS LTD.,
 Head Office: 199, Piccadilly, London, W.1. Regent 2828.
 Works: 260, High Rd., Balham, London, S.W. Battersea 8506.



BASICALLY BETTER...

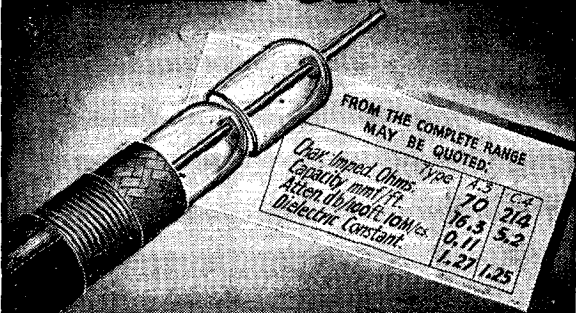

Air Insulation...

is the basic principle of
CO-AX CABLES
Unequaled H.F. Properties

There is a CO-AX Cable for every H.F. Purpose

TRANSRADIO LTD. Inc. TELEEQUIPMENT TO. 16 HIGHWAY-BEACONSFIELD

Exide

BATTERIES

FOR RADIO

are playing their part in the great national effort. They are as indispensable to the purposes of war as to those of peace

THE CHLORIDE ELECTRICAL STORAGE COMPANY LIMITED
Grosvenor Gardens House, Grosvenor Gardens,
London, S.W.1

B.I. CONDENSERS



for arduous conditions

B.I. Tropical Type Paper Condensers in Moulded Tubes, (U.K. Patent No. 506024 and application pending) are designed to operate continuously in extremely arduous conditions of temperature and humidity.

BRITISH INSULATED CABLES LTD.
Head Office: PRESCOT—LANCS. Tel. No: PRESCOT 6571

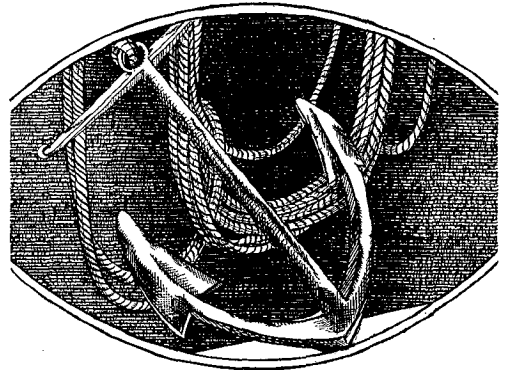

THIS ANCHOR DIDN'T HOLD

In a storm it was useless, because it wasn't made right and the ship nearly foundered. To make things right, to build stout integrity not only into our products, but into all our relationships and services, has ever been the aim, the fixed purpose of R • S Amplifiers. Which, of course, is one of the principal reasons why R • S products and services are now in demand in sterner fields and also why we are precluded from making available generally our normally wide range of Sound Equipment. If your customers, however, would like to know just what we can still supply, we'll gladly send you our most recent catalogue in exchange for a penny stamp.

R • S

AMPLIFIERS

R.S. Amplifiers, Ltd., 3-4, Highfield Road, Shepperton, Middx.
Telephone: Walton-on-Thames 1019.

WAXES OKERINS

AND DIELECTRIC MATERIALS

Cable, Condenser, Coil, Transformer and Resistance Impregnating, dipping, sealing, filling and finishing.

A.I.D. and C.I.E.M.E. TYPE APPROVED WAXES to meet both ARCTIC and TROPICAL conditions.

TELEPHONE: WEST DRAYTON 2189

**ASTOR BOISSELIER
& LAWRENCE LTD.**

MIDDLESEX OIL & CHEMICAL WORKS

WEST DRAYTON, MIDDLESEX

ROGERS

Postwar industry will be making wider use of industrial electronic technique developed during recent years. In this

work Rogers Radio Tubes—the tubes which opened the way to all-mains wireless—have played and will play a recognised part. Rogers with an established reputation for quality, produce all standard types of radio receiving tubes, power tubes for radio transmission, audio frequency amplification and industrial electronic applications generally. At present engaged solely on official work, they look forward to future co-operation over a wide field of industry.

ROGERS RADIO TUBES LTD.

TORONTO (ONTARIO) CANADA

A subsidiary of BROADCAST RELAY SERVICE LIMITED,
VICTORIA STATION HOUSE, VICTORIA ST, LONDON, S.W.1.

TAYLOR ALL WAVE SIGNAL GENERATOR

MODEL 83A



This new and improved generator operates from A.C. mains and covers a total range from 100 kilocycles to 46 megacycles in six wavebands, the dial being directly calibrated in frequency. The output is smoothly variable up to approximately 100,000 microvolts, and either internal modulation at 400 cycles or external modulation can be used. Iron cored coils are used on all bands. The instrument is thoroughly screened and a mains filter is fitted, reducing radiation to a minimum. A screened output lead is supplied with every instrument together with a book of instructions.

Price £14.14.0 complete.

We also manufacture a complete range of electrical measuring instruments and radio test equipment.
Model 83a is a 74 range measuring instrument, and is 4,000 ohms per volt A.C. and D.C. It measures up to 5,000 volts and to 10 amperes A.C. and D.C., and up to 10 megohms with internal batteries.

Price £15.15.0.

Taylor

electrical instruments Ltd.

Write for technical brochure
TAYLOR ELECTRICAL INSTRUMENTS LTD.,
419-424, Montrose Avenue, Slough, Bucks. Slough 21381 (4 lines)

On all the Seven Seas Condensers are at work



TRADE **HUNTS** MARK
The
Home of Condensers

ADVT. of A. H. HUNT LTD., LONDON, S.W.18. EST. 1901

B

Simmonds

Q M E T E R

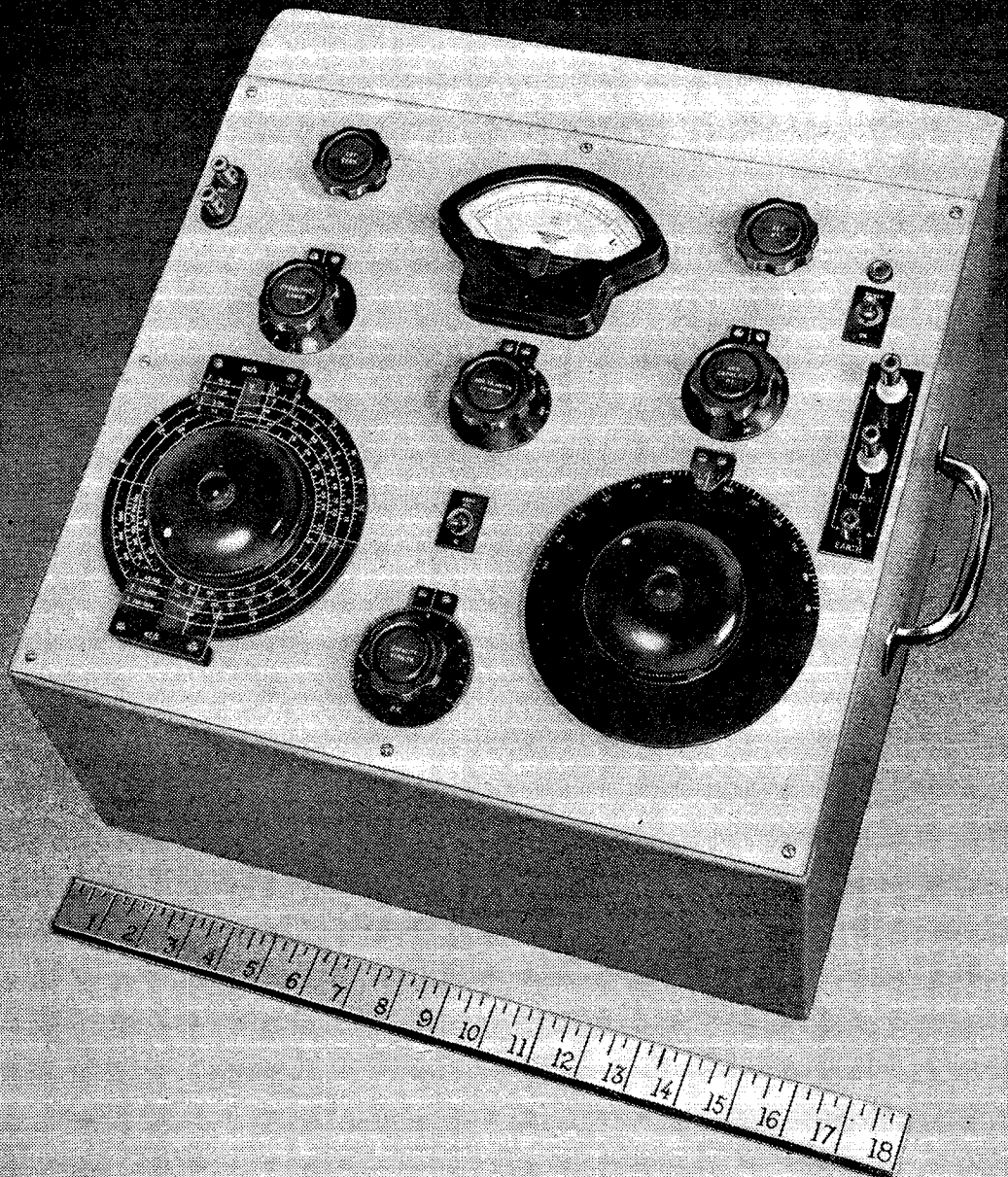

SIMMONDS AEROCESSORIES LTD · GREAT WEST ROAD · LONDON

A COMPANY OF THE SIMMONDS GROUP

LONDON · MELBOURNE · MONTREAL · PARIS · NEW YORK · LOS ANGELES

Wireless World

Radio • Electronics • Electro-Acoustics

33rd YEAR OF PUBLICATION

FEBRUARY 1944

EDITORIAL. Frequency Allocations	33
1944 : SUNSPOT MINIMUM YEAR. By T. W. Bennington	34
MEASURING SMALL INDUCTANCES. By R. F. Blackwell, B.Sc., and D. J. Becker	37
RADIO HEATING UNBIASED. By Free Grid	41
SIGNALS OFFICERS IN THE MAKING	43
MATCHING—II : Aerial and Intervalve Couplings at Radio Frequencies. By S. W. Amos, B.Sc. (Hons.)	47
RADIO DATA CHARTS—No. 14 : Inductance, Capacity and Frequency : IF Range. By J. McG. Sowerby, B.A., Grad.I.E.E.	50
WORLD OF WIRELESS	53
NEWS IN ENGLISH FROM ABROAD	54
FRAME AERIAL CONSTRUCTION. By R. E. Stace, A.M.I.E.E.	56
" WIRELESS WORLD " BRAINS TRUST	58
LETTERS TO THE EDITOR	60
RANDOM RADIATIONS. By " Diallist "	62
RECENT INVENTIONS	64

Branch Offices :

COVENTRY :

8-10, Corporation Street.
Telephone : Coventry 5210.

Telegrams :
" Autocar, Coventry."

BIRMINGHAM :

Guildhall Buildings,
Navigation Street, 2.

Telephone :
Midland 2971 (5 lines).

Telegrams :
" Autopress, Birmingham."

MANCHESTER :

260, Deansgate, 3.

Telephone :
Blackfriars 4412 (4 lines).

Telegrams :
" Iliffe, Manchester."

GLASGOW :

26B, Renfield Street, C.2.

Telephone : Central 4857.
Telegrams : " Iliffe, Glasgow."

△

As many of the circuits and apparatus described in these pages are covered by patents, readers are advised, before making use of them, to satisfy themselves that they would not be infringing patents.

Proprietors :
LILFFE & SONS LTD.

Managing Editor :
HUGH S. POCOCK,
M.I.E.E.

Editor :
H. F. SMITH.

Editorial, Advertising
and Publishing Offices:

DORSET HOUSE,
STAMFORD STREET,
LONDON, S.E.1.

Telephone :
Waterloo 3333 (35 lines).

Telegrams :
" Ethaworld, Sedist, London."

△

PUBLISHED
MONTHLY

Price : 1/6

(Publication date 25th
of preceding month)

Subscription Rate :
Home and Abroad
20/- per annum.

Miniature I.F. Transformers

DESIGNED FOR MAXIMUM
GAIN AND SELECTIVITY IN
THE SMALLEST DIMENSIONS

The coils are contained in enclosed pot-type iron dust cores, tuning adjustments being obtained by means of adjustable iron dust centre cores.

Fixed tuning condensers are contained inside the screening can.

Units are made with a number of variations in windings and coupling coefficients for certain circuit conditions, but five standard types are recommended for general use.

Wartime restrictions prevent our accepting orders other than those covered by priority numbers.

The illustration shows the actual size of the Unit which is provided with one hole fixing, the terminal wires being fed through insulated bushings which, in turn, prevent movement of the transformer when mounted in position.

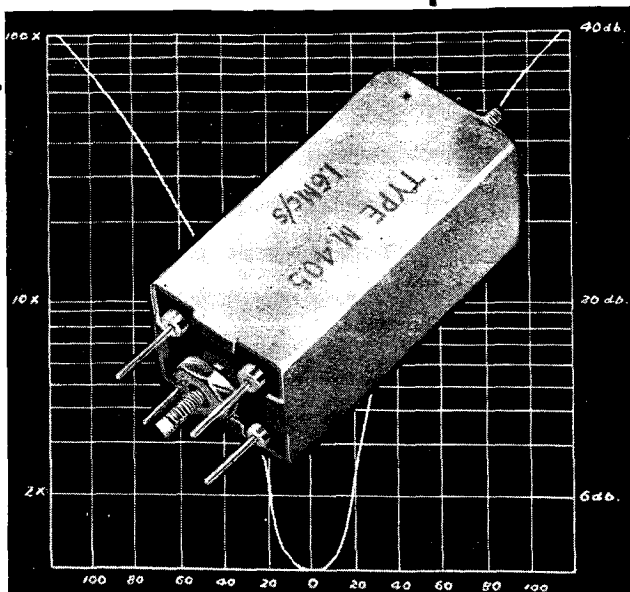

WRIGHT & WEIRE LTD.

HIGH ROAD, TOTTENHAM, N.17.

Telephone : TOTtenham 3847-8-9.

*Over twenty years of
experience and research
are behind the advanced
technique of today . . .*



MULLARD
THE MASTER VALVE
A Valve for Every Purpose

DOMESTIC · COMMERCIAL · INDUSTRIAL · SCIENTIFIC · MEDICAL · EXPERIMENTAL

THE MULLARD WIRELESS SERVICE CO. LTD., CENTURY HOUSE, SHAFTESBURY AVENUE, LONDON, W.C.2. (75

Wireless World

Radio • Electronics • Electro-Acoustics

Vol. L. No. 2

FEBRUARY 1944

Price 1s. 6d.

Frequency Allocations

Need for an Interim International Plan

FEW will disagree with the general principle that, whatever happens after the war, the industrial transition to peacetime production must take place with the minimum of delay. That, it can safely be assumed, is an issue beyond all political controversy, and we can safely accept the axiom that there must be no unnecessary waste of time in starting to produce the goods for which the whole world stands so sorely in need.

Even the most optimistic among us expect many obstacles—some natural, but probably many more artificial—in the way of a quick change-over from war- to peacetime production in the wireless industry. Of these artificial obstacles, that of international frequency allocation for the various wireless services is by no means inconsiderable. Unless the industry knows what frequency bands are to be used, it cannot embark with confidence on large-scale manufacturing programmes.

Older readers will remember what happened in the early 1920's, when the possibilities of short waves were first experimentally explored. Our state of knowledge was then such that we chose frequencies, not necessarily because they were best for the job in hand, but because they were those on which our transmitters could be persuaded to oscillate and our aerials to radiate. Similarly, with regard to the ultra-short waves, it is not an exaggeration to say that we were at a hardly more advanced state of development at the time of the Cairo Convention in 1938, when the distribution of frequencies that is still effective was made. It seems to be widely agreed that some of the ultra-short-wave allocations then made were decided upon as a matter of expediency, and largely because results had, in fact, been obtained on the frequencies allotted. In some cases it is believed that, in the light of increased knowledge, better allocations could now be made. There is also the question of finding room for peacetime applications of brand-new wartime developments.

The need for reconsideration of frequency allocations may be emphasised by referring to proposals, reported in our December, 1943, issue, for the immediate post-war establishment in this

country of a combined television and FM sound broadcasting service on, roughly, the frequency band 40-65 Mc/s. It may not be realised that that scheme involved the need for some alteration of existing frequency allocations; strictly speaking, it could not be put into effect without a new international agreement. Indeed, that might well apply to any technically desirable television scheme.

Anarchy on USW

It is sometimes argued that, as ultra-short waves have a strictly local range, there is no need for international agreement as to their use. Although there is something to be said for that argument, provided one confines oneself to frequencies well over 50 Mc/s, we think it reflects an insular outlook that is foreign to the true nature of wireless. What will happen if other nations decide, say, to use as navigational aids for aircraft and shipping those frequencies that we choose for our television service? Having accepted the "free-for-all" principle, we could hardly complain if, during foggy weather, television reception became impossible along a fairly deep coastal belt extending from Land's End to Dover.

If we accept the principle that some measure of international agreement is needed even for ultra-short-wave allocations, the inevitable conclusion is that an international convention should be called even before the war ends. To suggest such a thing during a world war may seem mildly ridiculous. But, although a full-dress meeting of the nations is clearly out of the question, we do suggest that it should be possible to arrange a convention of limited scope to settle those matters that will affect large-scale production. Already serious suggestions have been made for international conferences on other matters, and, in our own sphere, the Federal Communications Commission in U.S.A. has called a domestic conference to deal not only with FM and television frequency allocations but with other matters of a more international significance. Unless something is done quickly, we may have to wait in a state of uncertainty for years for a real International Convention.

1944 : SUNSPOT MINIMUM YEAR

Effects on Wireless Communication

By T. W. BENNINGTON

DURING 1944 an event of some considerable importance to short-wave communication is expected to occur—the present sunspot cycle is expected to reach its minimum. When this happens, as it does once in about every 11 years, it would seem that the solar activity has arrived at a dead low level, and that those of the sun's radiations which perform the work of ionising the gases of the high atmosphere have reached an approximately minimum intensity. Thus the gases are more weakly ionised than at any time in the 11 years, the refracting power of the ionised gas on radio waves is less, and, in consequence, lower frequencies have to be used for long-distance communication than at any time during the cycle. After 1944 the solar activity—as shown by the size and frequency of the sunspots—is expected to increase again, and to go on doing so for about five years, until the epoch of maximum activity is again reached. We are thus, at present, mainly concerned with phenomena which are associated with the minimum of the cycle, so let us go into some of these in a little more detail.

In the first place, how comes it that we should expect the mini-

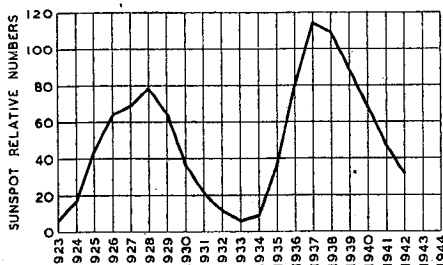
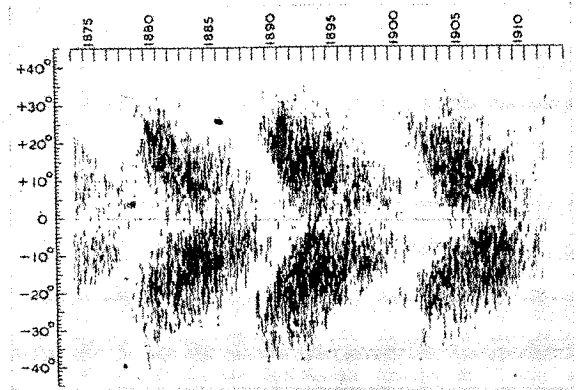

Fig. 1. Annual means of relative sunspot numbers.

mum of the cycle to occur in 1944? It is interesting to note in this connection that, although R. Wolf established a mean period of 11.1 years for the duration of a sunspot cycle, the actual duration of the cycles varies considerably. For instance, if the annual means of the relative sunspot numbers are examined for the period between the sunspot minimum of 1755 and that of

1933, it is found that during the 178 years there occurred two cycles of about nine years' duration, four of about ten years, four of about 11 years, three of about 12 years, two of about 13 years and one of about 14 years' duration. So obviously we cannot count on a cycle reaching its minimum at the end of 11 years.

Fig. 2. Distribution, in terms of latitude on the sun's surface of sunspot centres for the years 1874-1913. (From "The Sun," by Giorgio Abetti; Crosby, Lockwood and Son.)



But although we cannot be at all certain in the case of the present cycle, yet strong evidence has been obtained that its minimum will be reached in 1944.

One indication is provided by a study of the sunspot numbers for the past few years, noting the trend in their values. The system of "relative sunspot numbers" was invented by Wolf as a means of measuring and recording the sunspot activity, and takes into account the number of sunspot groups and also the number of individual spots observed at different ob-

servatories. The "number" fluctuates fairly violently from month to month, but it will be sufficient for our purpose if we study only the annual mean value, whereby the trend of the variation will be shown up quite clearly. Fig. 1 is a graph of these annual means for the years 1923 to 1942, comprising part of the present cycle and the whole of its predecessor. It is seen that if the

graph is extrapolated towards the future years, using the values for the past few years as a guide, there is every indication that in 1944 a minimum will again be reached.

Another interesting phenomenon is the change in the position of the sunspots as the cycle proceeds in its course. The first spots of the cycle appear in two belts which are situated in about 30 deg. North and South solar

latitude, and, as the cycle proceeds, these belts drift nearer to the solar equator, until, at the end of the cycle, they lie in about 8 deg. North and South latitude. But, somewhat before the time of minimum activity, the high-latitude spots again begin to appear, so that, at that time, the spots are appearing in four belts, two in high and two in low latitudes, on either side of the solar equator. The first high-latitude spots to appear may, therefore, be regarded as the beginners of a new cycle, and their appearance to indicate that the current cycle is coming to an end. Such high-latitude spots have, during the past few months, already been observed, and thus provided the astronomers with another indication as to the time of minimum sunspot activity in the present cycle. The change in the latitude of sunspots as a cycle proceeds is best shown by the "butterfly" diagram of Maunder, a reproduction of which is given in Fig. 2, for the years 1874 to 1913. During this period sunspot

minima occurred in 1878, 1889, 1901 and 1913.

Another indication of the close of a sunspot cycle is the reversal in the magnetic polarity of the bi-polar spots which takes place at that time. The sunspots most often appear as groups of two predominating spots, though these may be accompanied by many small spots. Of the two predominating spots, that lying in the advanced position with regard to the direction of rotation of the sun is called the "leader" spot, and the other is known as the "follower." In the great majority of such groups, the leader and follower are of opposite magnetic polarity, and such bi-polar spots maintain the same polarity during any one cycle. Polarity is in the opposite sense in the two hemispheres. The first spots of a new cycle, however, have an opposite magnetic polarity to those of the old cycle; i.e., there is a reversal in polarity in the two hemispheres. This reversal in polarity has already been observed in the case of a few sunspots by the Mount Wilson Observatory, indicating that some of the sunspots belong to a new cycle.

Effects on Communications

The indications that the sunspot minimum is fast approaching appear, therefore, to be fairly strong, though, as has been said, the precise time of its occurrence cannot be foretold with certainty. But how does all this affect wireless communication, and what steps must be taken to meet it?

Our information as to the electrical state of the ionosphere gases is provided by the measurements of "critical frequency" of the ionosphere layers which are constantly going on at many places throughout the world, and by the study of past records of this critical frequency we can trace the effect of the solar cycle on ionisation. Readers are reminded that the "critical frequency" of a layer is the highest frequency which is returned from the layer when the wave is sent vertically upwards. It is thus a measure of the ionisation level existing in the layer, and also of the intensity of the ionising solar radiation. When the radiation is strong the ionisation—generally speaking—will be high, and the critical fre-

quency will also be high, whilst a decrease in the intensity of the radiation will lead to a decrease both in the ionisation and in the critical frequency.

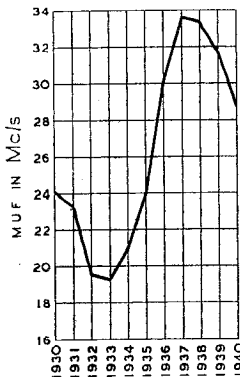

Fig. 3. Annual average of the noon "maximum usable frequency" for Washington. (Calculated from critical frequency data published by the National Bureau of Standards, U.S.A.)

Measurements of the critical frequency were only started about thirteen years ago, so we have no records of this quantity for former sunspot cycles. The ionisation, and hence the critical frequency, will, of course, vary greatly from day to night and also from summer to winter, so we have the diurnal and seasonal variations superimposed on those due to the sunspot cycle. But if we take, for., say noon only, the annual mean of the critical frequency for any one place and so eliminate the diurnal and seasonal variations, we can compare this directly with the annual mean of the sunspot numbers and see whether the two quantities rise and fall in sympathy. Actually it is even more informative to

TABLE I.—MAXIMUM USABLE FREQUENCY AT THE LATITUDE OF WASHINGTON DURING WINTER AND SUMMER OF SUNSPOT MAXIMUM AND MINIMUM YEARS

Year	Month	MUF at Noon (Mc/s)	MUF at Midnight (Mc/s)
1933	June	16.0	10.0
1937	June	22.3	17.7
1933	December	21.0	6.4
1937	December	42.8	12.7

calculate, from the annual mean of the measured critical frequencies, the corresponding "maximum usable frequencies" for long-distance communication. If we do this for 3,500 km. we shall have the annual mean of the highest frequency which it was theoretically possible to use during the years we are considering. In Fig. 3 this has been done for the years 1930 to 1940, on the basis of ionosphere measurements made at Washington. Although we cannot now publish these values for the later years, yet if we compare Fig. 3 with Fig. 1 we see at once that the highest frequency usable does rise and fall in accordance with the degree of solar activity. Table I also shows what large variations take place in the highest usable frequencies as between sunspot maximum and minimum, particularly during the winter daytime.

It is interesting to look at the winter daytime values for 1937 as shown in this table, and to compare them with the highest frequencies actually in use for long-distance communication at that time.

So at sunspot minimum the working frequencies are, generally speaking, very low. Now it is a good principle in short-wave work to make use of the highest frequency on which it is possible to work. For one thing, the atmospheric noise increases in an approximately square law manner as frequency is reduced. For another, if the high limiting frequency is brought lower and lower it means that the width of the workable band is made narrower, and as the number of stations working is not correspondingly reduced it results in a congestion of stations on the lower short-wave frequencies. We get the situation where all sorts of low-power stations—designed to give only a limited local service—begin to provide signals of world-wide range, whilst the more powerful stations are crowded into a narrow band which is not wide enough to accommodate them. But they are forced into this situation, because if they work on higher frequencies their waves just go through the ionosphere and escape. Such a situation prevails at the sunspot minimum, when the ionisation is very low and the higher frequen-

1944: Sunspot Minimum Year—

cies unusable. It prevails more particularly during the night-time at the sunspot minimum, and especially during the winter night-time, when the situation is likely to be about as bad as it possibly can be, because then the ionisation will be lower than at any time in the eleven years of the cycle. So we can hardly look forward to the sunspot minimum with any pleasure, for at that time, because they are forced to work on the lower frequencies, where the disturbing factors, both natural and man-made, are particularly numerous, short-wave stations will, generally speaking, maintain their services only with difficulty.

To sum up this situation we may say that, at the sunspot minimum, only the relatively lower frequencies of the short-wave range will be of use, and that, whilst during the daytime the result may not be so bad as adversely to affect reception, during the night conditions are more likely to be poor, owing to the congestion of stations and the high atmospheric noise level.

This is one further point which should not be forgotten. During ionosphere disturbances there is a further *abnormal* reduction in the ionisation of the refracting layers. When the normal level of ionisation is already high this may not be serious, for under these conditions one can afford to lose some of the ionisation without it seriously affecting the usual working frequencies; it may even be possible to lower the working frequency in order to take account of the fall in ionisation. The effects of an ionosphere storm are never so serious, for example, during the day as they are during the night. At the sunspot minimum the prevailing ionisation is already so very low that a slight further fall

due to an ionosphere disturbance almost always results in a serious deterioration in reception—particularly at night. And as most stations are already working on the lowest frequencies available it is not possible further to lower the working frequency at the sunspot minimum. Therefore the effect of ionosphere disturbances is likely to be more

Fig. 4. Annual means of relative sunspot numbers for years around the last five periods of minimum activity.

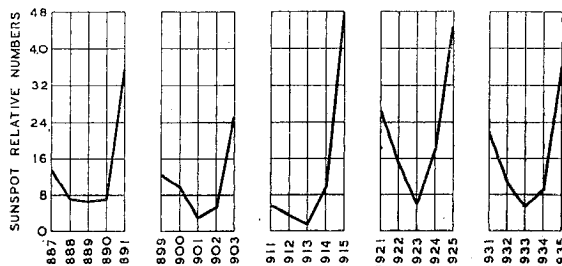

strongly felt—in deterioration of short-wave communication—than at any other time in the 11 years. And the disturbances (peculiarly enough, since they themselves are thought to be strongly connected with sunspot activity) still continue to occur at frequent intervals throughout the sunspot minimum.

An important question which now naturally arises is this: If the minimum of the cycle occurs during 1944 may we expect a large increase in the solar activity to follow immediately, with a consequent increase in the atmospheric ionisation and in the highest frequencies usable for short-wave work?

Well, this certainly did not immediately follow the last minimum, for a glance at Figs. 1 and 3 will show that though the minimum occurred in 1933, it was not until 1935 that there was any considerable increase in either the sunspot activity or in the usable frequencies. But we cannot base our ideas solely on what happened at the last sunspot minimum, for this may not have run true to form. Unfortunately we have no

radio data available for the former cycles, but, as we have already seen, the highest radio frequencies of use do, in general, increase and decrease in accordance with the increase and decrease in sunspot numbers. So we may be justified in examining the sunspot numbers

only, with a view to finding out what is likely to happen.

Suppose, therefore, we examine the sunspot records for the last five minimum periods, i.e., the minima occurring in 1889, 1901, 1913, 1923 and 1933. Table II gives the annual mean of the observed relative sunspot numbers for all these years, together with that for the two years preceding and following the minimum period. Fig. 4 gives the values in graphical form, and it is seen that in all cases—except perhaps in that of the 1923 minimum—there was no big increase in sunspot activity during the first year after the minimum. In all the cases a really big increase took place during the second year after the minimum; namely, in the years 1891, 1903, 1915, 1925 and 1935. Even the last five cycles of sunspot activity may not be a sure indication of what is likely to happen during the next one, but an examination of the records back to 1755 shows that, of the 17 minimum periods which have occurred since that date, during only three of these was there any considerable increase in activity during the first year after the minima. So it is, perhaps, a fair conclusion to say that there is unlikely to be any large increase in the highest radio frequencies of use for long-distance communication until 1946. And, after that year, we are likely to see regular long-distance short-wave communication taking place on higher and higher frequencies—on frequencies, as a matter of fact, which have never been exploited for this purpose before.

TABLE II.—ANNUAL MEANS OF RELATIVE SUNSPOT NUMBERS FOR YEARS AROUND MINIMUM. (Figures for minimum years in heavy type)

Year	Sun-spot Nos.	Year	Sun-spot Nos.	Year	Sun-spot Nos.	Year	Sun-spot Nos.	Year	Sun-spot Nos.
1887	13.1	1899	12.1	1911	5.7	1921	26.1	1931	21.2
1888	6.8	1900	9.5	1912	3.6	1922	14.2	1932	11.1
1889	6.3	1901	2.7	1913	1.4	1923	5.8	1933	5.7
1890	7.1	1902	5.0	1914	9.6	1924	16.7	1934	8.7
1891	35.6	1903	24.4	1915	47.4	1925	44.3	1935	36.1

MEASURING SMALL INDUCTANCES

An Instrument for the Rapid Measurement of the Inductance and Self-capacitance of Coils from 1 to 1000 μH

THERE are two general methods of measuring low values of inductance: (a) the bridge, in which an unknown inductance is balanced in an AC bridge against a standard inductance or capacitance, and (b) resonance, in which a condenser of known value is connected to form a tuned circuit with the coil. The resonant frequency is found by injecting a variable-frequency signal into the tuned circuit and noting the frequency at which either maximum current in the case of a series circuit, or maximum voltage in the case of a parallel circuit, occurs. A variation of this method is to use a fixed frequency and vary the standard condenser. The inductance is then calculated from the formula $L = 1/\omega^2 C$. The effect of coil and condenser losses on the resonant frequency is, with the usual types of coils, small enough to be neglected, except for measurements of the highest precision.

At the low frequencies used on the majority of bridges, the impedance of normal low-inductance coils is largely resistive, and careful balancing of both the inductive and resistive components is necessary to obtain high accuracy. Bridges using high-frequency sources are more convenient to adjust, but these require careful design and adequate shielding between the various parts.

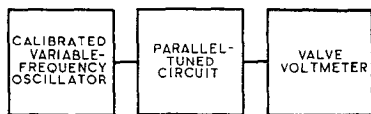

Fig. 1. Schematic layout of inductance tester.

The resonance method is more suited to the rapid checking of inductance where extreme accuracy is not required. It has the further advantage that, by taking readings at two different frequencies, the self-capacitance of the coil can be calculated and the

By

R. F. BLACKWELL,

B.Sc., and

D. J. BECKER

(Murphy Radio, Ltd.)

true inductance, without the effect of self-capacitance, found.

With bridge and single-frequency resonance methods, the frequency is chosen to be low enough to ignore the shunting effect of the self-capacitance, which at high frequencies reduces the impedance of the coil and gives an apparent inductance value lower than the true value.

Theory

The instrument to be described is based on the two-frequency resonance method. A disadvantage of the usual resonance methods in comparison with bridge measurements is that the value of the inductance is not shown directly. In the present instrument the inductance is given merely as the difference between two readings on a calibrated scale; in addition, the self-capacitance may be readily calculated. The largest observed error in the inductance measurement is of the order of 0.5 per cent. The maximum measurable inductance is about 1000 μH ; above this value, coils of normal Q can be conveniently measured on LF bridges.

Referring to Fig. 1, it will be seen that the output from a variable-frequency oscillator is fed into a parallel-tuned circuit consisting of the coil of unknown inductance and either of two condensers of known value, switched across the coil in turn. The frequency of the oscillator is varied until resonance, as shown by the valve voltmeter, is obtained in each case.

Let the unknown coil (Fig. 2) have an inductance of $L \mu\text{H}$ and a self-capacitance of $C_0 \mu\mu\text{F}$. Call the known switched capacitances

C_1 and $C_2 \mu\mu\text{F}$ ($C_1 > C_2$) and the resonant frequency of tuned circuit $f_1 \text{ Mc/s}$ with C_1 and $f_2 \text{ Mc/s}$ with C_2 .

Let the first reading on the calibrated oscillator condenser be X, and the second Y.

The calibration of the oscillator condenser is arranged so that if an inductance of value X or $Y \mu\text{H}$ were connected in parallel with capacitance of $C_2 \mu\mu\text{F}$, the resonant frequency of the tuned circuit so formed would be f_1 or $f_2 \text{ Mc/s}$ respectively.

Then the resonant frequency f_1 of the tuned circuit formed by C_1 , C_0 and L is given by:

$$f_1 = \frac{1000}{2\pi\sqrt{L(C_1 + C_0)}} \quad \dots (1)$$

(see footnote*)

Also the first reading X on the calibrated condenser (i.e. the inductance required to tune a

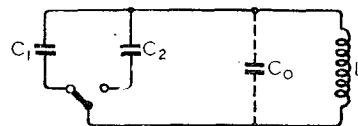

Fig. 2. Test-coil circuit.

capacitance $C_2 \mu\mu\text{F}$ to a frequency $f_1 \text{ Mc/s}$ is given by

$$f_1 = \frac{1000}{2\pi\sqrt{XC_2}} \quad \dots (2)$$

Hence from (1) and (2),

$$\frac{1000}{2\pi\sqrt{L(C_1 + C_0)}} = \frac{1000}{2\pi\sqrt{XC_2}}$$

$$\therefore XC_2 = L(C_1 + C_0) \quad (3)$$

Similarly the resonant frequency $f_2 \text{ Mc/s}$ of the tuned circuit formed by C_2 , C_0 and L, and the second reading Y on the calibrated condenser may be found, the result being

$$YC_2 = L(C_2 + C_0) \quad \dots (4)$$

* If F is in c/s, L in henries and C in farads, $F = 1/2\pi\sqrt{LC}$, but for an inductance $L' \mu\text{H}$ and a capacitance $C' \mu\mu\text{F}$, the frequency in Mc/s is given by

$$10^6 \times F' = 1/2\pi\sqrt{L' \times 10^{-6} \times C' \times 10^{-12}},$$

or $F' = 1000/2\pi\sqrt{L'C'}$.

Measuring Small Inductances—

From (3) and (4) by expanding,

$$XC_2 = LC_1 + LC_0 \quad \dots (5)$$

$$YC_2 = LC_2 + LC_0 \quad \dots (6)$$

Subtracting (6) from (5),

$$XC_2 - YC_2 = LC_1 - LC_2$$

$$\therefore C_2(X - Y) = L(C_1 - C_2)$$

By rearranging,

$$L = \frac{C_2}{C_1 - C_2} \cdot (X - Y) \quad (7)$$

Dividing (5) by (6),

$$\frac{X}{Y} = \frac{L(C_1 + C_0)}{L(C_2 + C_0)} = \frac{C_1 + C_0}{C_2 + C_0}$$

$$\therefore X(C_2 + C_0) = Y(C_1 + C_0)$$

$$C_0 = \frac{YC_1 - XC_2}{X - Y} \quad \dots (8)$$

Hence it will be seen that X is larger than 2L and Y is larger than L, by an amount LC_0/C_2 . If it is arranged that C_2 is never less than $2C_0$, then for the range $1 - 10 \mu H$, a convenient calibration would be $1 - 25$ and correspondingly for the ranges $10-100$ and $100-1000 \mu H$, the calibrations would be $10-250$ and $100-2500$ respectively.

A calibration range of $1-25$ requires a variable condenser having a ratio of maximum to minimum capacitance of $25:1$ (see footnote †); this would be inconvenient in practice, as the minimum capacitance is limited by circuit strays and thus a very large condenser would be required. It was decided, therefore,

to split each range into two parts, having calibrations of $1-5$ and $5-25$ respectively, the condenser then requiring a capacity ratio of only $5:1$.

There are four scales, as shown in Fig. 3; scales A and B are connected with the variable condenser and

condenser has a linear capacity law and therefore the scales A and B are linear. It was decided that a minimum of $50 \mu\mu F$ would allow a reasonable margin for stray capacitances in coils, switching and wiring; therefore, as the capacity ratio is $5:1$, the maximum of the condenser is $250 \mu\mu F$.

The circuit of the variable oscillator is of the back-coupled, tuned-anode type, using a high-slope RF pentode (Mazda SP41) (see Fig. 4). There are six positions on the coil-switch (scale C), giving multiplying factors for scales A and B of $1, 10$ and 100 . Two six-way switch-wafers are used, and are of the type that connects together all contacts except the one in use; this prevents any possible absorption from the coil in circuit by adjacent coils. Each coil has an adjustable dust core and a separate trimmer condenser, allowing maximum and minimum frequencies to be set on each position.

The tuned circuit, consisting of the coil of unknown inductance and one of the known condensers, is loosely coupled through a $1 \mu\mu F$ condenser to the grid of the oscillator circuit. The voltage across the grid coil shows less variation in amplitude than that across the anode coil, owing to grid-current damping. Although the waveform at this point contains more harmonics, no trouble is experienced in practice from spurious resonances. The increased reactance of the coupling condenser at the lower frequencies partially compensates for the increased dynamic resistance of the larger coils measured at these frequencies; the amplitude of the voltage at resonance therefore tends to remain constant.

The condensers C_1 and C_2 have values of 40 and $20 \mu\mu F$ respectively for coils from 1 to $100 \mu H$, and 400 and $200 \mu\mu F$ for coils from 100 to $1000 \mu H$. It was found desirable to have large values of C_1 and C_2 for coils of higher inductance in order that the increased self-capacitance of such coils shall not upset the relation that C_2 shall not be less than $2C_0$. The small values are necessary with low-inductance coils in order to keep the resonance sharp. This arrangement allows coils to be measured at frequencies approaching those at which they are normally used.

If C_1 and C_2 are chosen so that $C_1 = 2C_2$, then from (7),

$$L = \frac{C_2}{2C_2 - C_2} \cdot (X - Y) = X - Y \quad \dots (9)$$

and from (8),

$$C_0 = \frac{2YC_2 - XC_2}{X - Y} = \frac{C_2(2Y - X)}{X - Y} \quad \dots (10)$$

Equation (10) may be written

$$C_0 = n \cdot \frac{2Y - X}{X - Y}$$

where n is a factor whose value is the capacitance of C_2 .

From (5) by substituting $C_1 = 2C_2$,

$$XC_2 = 2LC_2 + LC_0$$

$$\therefore X = 2L + LC_0/C_2$$

and from (6), $Y = L + LC_0/C_2$.

give values of X and Y; scale C is connected with the coil switch of the variable oscillator and gives multiplying factors for X and Y, and scale D is connected with the switch that changes the capacitances of C_1 and C_2 , and gives values of n .

It has already been shown (see footnote †) that if the condenser has a certain capacity law, the calibrations of scales A and B will follow the same law. The

† Let $L_p \mu H$ be inductance in circuit of variable oscillator.

Let f_s Mc/s be frequency of oscillator when capacitance is $C_2 \mu\mu F$.

Let Z be reading on scale A or B, when capacitance is $C_2 \mu\mu F$.

Let $C_s \mu\mu F$ be smaller of known condensers switched across unknown coil.

Then $f_s = 1000/2\pi\sqrt{L_p C_s} = 1000/2\pi\sqrt{Z C_s}$. Hence $Z = (L_p/C_s) \cdot C_s$, and as L_p/C_s is constant for any given range, Z must vary directly as C_s . Hence for a range of reading of $25:1$, C_s must have a capacity ratio of $25:1$.

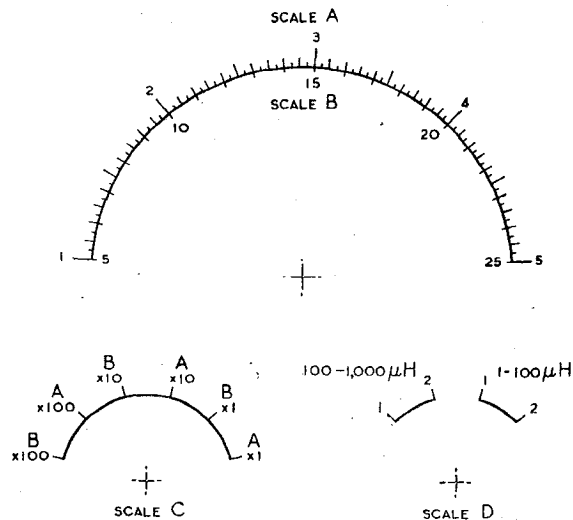

Fig. 3. Scales engraved on the front panel of the instrument.

The valve voltmeter consists of a television-type diode (Mazda D1) as rectifier, the resultant positive voltage being fed on to the grid of a biased-off meter-control valve. The leads in the diode section are kept short and almost all the losses are due to the damping resistance of the diode. Sensitivity is varied by altering the bias voltage on the meter-control valve. A 100,000 ohm resistor is connected in series with the 1 mA meter to limit the anode current in the event of an overload; this has no appreciable effect at lower currents. The meter reading will indicate the comparative Q's of similar coils, if readings are taken on the same position on scale D. Although the valve voltmeter reading varies almost linearly with Q, the meter control valve is normally biased past cut-off and the lower end of the Q scale will therefore be suppressed, the degree of suppression depending on the setting of the sensitivity control.

The instrument was set up in the following manner. The variable condenser used was found to have a maximum linear variation

Range (μH)	Scale C switch position	Oscillator inductance (μH)	Frequency (Mc/s) at scale A position:	
			1	5
1 to 10	A \times 1	0.4	35.6	15.9
10 to 100	B \times 1	2.0	15.9	7.12
10 to 100	A \times 10	4.0	11.25	5.03
100 to 1000	B \times 10	20.0	5.03	2.25
100 to 1000	A \times 100	400.0	1.125	0.503
1000 to 10000	B \times 100	2000.0	0.503	0.225

of 212 $\mu\mu\text{F}$ and two points 200 $\mu\mu\text{F}$ apart were used for the 1 and 5 points on the calibrated scale A (see Fig. 3). Points 2, 3 and 4 corresponded to increases of 50, 100 and 150 $\mu\mu\text{F}$ respectively from the point 1.

The four fixed switched capacitances were adjusted by means of trimmer condensers to values of 400 and 200 $\mu\mu\text{F}$ for positions 1 and 2 on the 100 to 1000 μH range and 40 and 20 $\mu\mu\text{F}$ for positions 1 and 2 on the 1 to 100 μH range. The values were measured across the test terminals, so that they are inclusive of circuit strays and the diode input capacitance.

A signal generator, previously checked against a multiple crystal

oscillator, was used as a standard for adjusting frequencies on each range. Each oscillator coil has an adjustable iron-dust core and a trimmer condenser (see Fig. 4). Frequencies were adjusted at positions 1 and 5 on scale A to the values given in the table above.

The frequencies on the various ranges at positions 5 (scale A) were adjusted with the iron-dust cores and at 1 with the trimmer condensers. As one adjustment has some effect on the other, this process must be repeated several times.

The coil of unknown inductance is connected across the test-terminals. The scale D switch is set to position 1 on the 1-100 μH

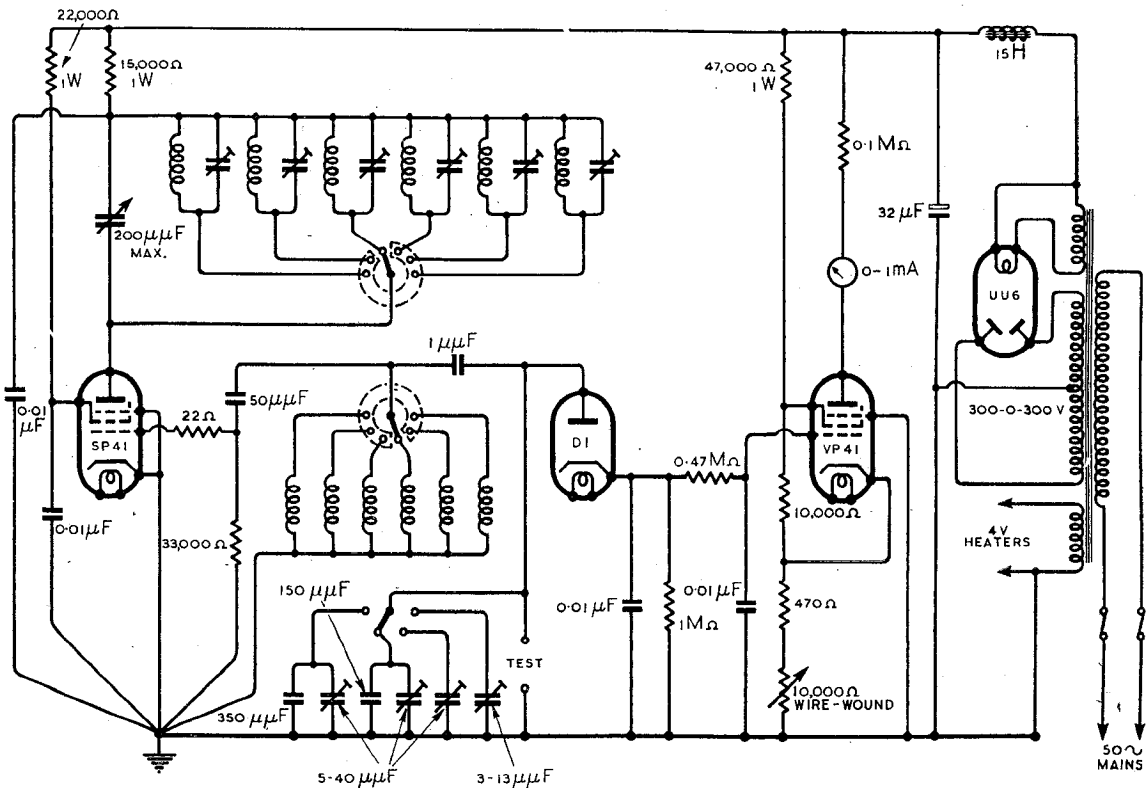
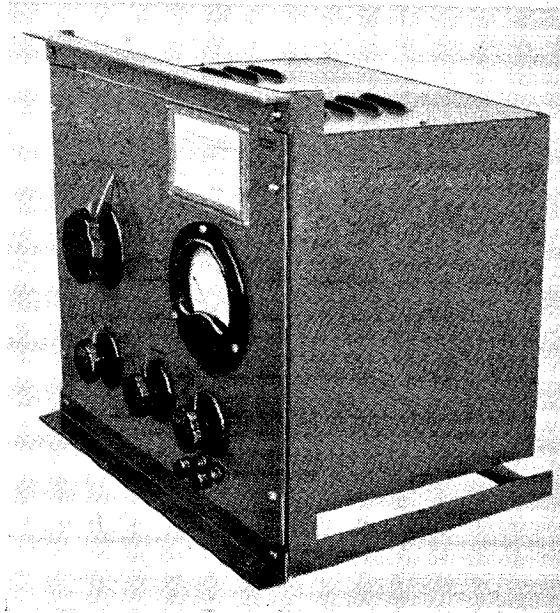

Fig. 4. Complete circuit diagram of inductance and self-capacitance tester.

Measuring Small Inductances—range if the coil is small, or to position 1 on the 100–1000 μH range if the coil is larger. It is usually possible to estimate visually the approximate inductance and hence the correct range to use. The sensitivity control is adjusted until the meter just shows a reading. The point of resonance can then be quickly found by switching to possible positions on the scale C switch,

General view of inductance tester. The sensitivity control is between the "C" and "D" scales in the bottom row.



and rapidly rotating the variable condenser. Once the resonance point has been found, sensitivity usually has to be reduced. The reading (X) on scale A or B is noted, the multiplying factor on scale C being taken into account. The scale D switch is then set to the appropriate position 2 and the point of resonance again found. The new reading Y is noted. The coil inductance is $(X - Y) \mu\text{H}$ and the self-capacitance is $n \cdot (2Y - X) / (X - Y) \mu\mu\text{F}$, where n

(the value of C_2 in $\mu\mu\text{F}$) is 20 on the 1–100 μH range (scale D) and 200 on the 100–1000 μH range. It will be found that X is rather larger than $2L$ and Y is rather larger than L .

It is possible, by using two variable condensers in parallel as the oscillator tuning capacitance, to have a directly calibrated inductance scale on one of these. The calculation of C_0 is complicated, however. The method would be useful for the measurement of inductance where knowledge of C_0 is not required.

In conclusion, the authors wish to express their thanks to Murphy Radio, Ltd. for permission to describe this apparatus.

BOOK REVIEW

Time Bases (Scanning Generators). By O. S. Puckle, M.I.E.E. Pp. 204; Figs. 124. Published by Chapman & Hall, Ltd., 11, Henrietta Street, London, W.C.2. Price 16s. net.

IF evidence of the growing importance of the cathode-ray tube as a tool in the hands of the electronic engineer were needed, the existence of this book, concerned as it is chiefly with the various types of time bases which can be employed in conjunction with the CR tube, could be cited.

As Dr. E. B. Moullin points out in his foreword, an authoritative book on the construction, testing and uses of time bases is already

overdue. Mr. Puckle is perhaps most widely known for his "hard valve" time-base circuit, using a variation of the multivibrator circuit for condenser charging. The author modestly devotes only about $4\frac{1}{2}$ pages to this in the book, but he has carried out considerable experimental and development work in the field of cathode-ray work, and the book is therefore written by one having a wide knowledge.

The author has endeavoured to treat the subject historically, and has included many early devices which, though they were not employed to any extent at the time, may yet prove useful in certain applications of the CR tube.

The book opens with a description of the various types of time bases, including sinusoidal, circular, soft-valve linear and hard-valve linear. The next chapter deals with single and 2-valve trigger circuits, and this is followed by one on blocking oscillators and inductive time bases. Polar co-ordinate, multiple and velocity modulation time bases are then considered.

Where an extreme degree of linearity is essential (and with all known "constant current" charging circuits some error is present) it is necessary to undertake what the author describes as "linearisation of the trace," and there is a chapter on this subject, including also methods of checking linearity.

The important subject of push-pull deflection occupies another chapter, which gives details of five important methods of screening it; this is followed by short chapters on synchronisation and the use of time bases for frequency division.

The last quarter of the book is devoted to a number of appendices dealing with matters which cannot be fitted in logically elsewhere.

A feature of the book, which will appeal to the average engineer, is that it is not loaded with mathematics; it is, on the contrary, very readable. There are many references for those who wish to study original papers. W. E. M.

USING CR TUBES

THE ever-widening use of cathode-ray tubes is reflected by the recent issue of a War Emergency British Standard Code of Practice relating to their application to various purposes. The Code, which has been prepared by a committee of CR tube manufacturers working in collaboration with the B.R.V.M.A., discusses such matters as ratings, heater voltage regulation, mounting, ventilation, heater-cathode insulation and various safety precautions, such as the provision of protective resistors.

It is stressed that tubes cannot normally be specially selected for individual requirements, and that equipment should be so designed that it will work satisfactorily with tubes of characteristics tending towards the extremes of the limits allowed.

Copies of the leaflet (BS1147: 1943) are obtainable, price 6d. by post, from British Standards Institution, 28, Victoria Street, London, S.W.1.

GOODS FOR EXPORT

The fact that goods made of raw materials in short supply owing to war conditions are advertised in this journal should not be taken as an indication that they are necessarily available for export.

RADIO HEATING

Industrial Applications of Eddy Current and Dielectric "Losses"

THERE has been a good deal of talk lately of the wonders of heating by wireless and the "new" science of "heatronics" which is to revolutionise industry and domestic life in the Brave New World. Much of this is speculation and wishful thinking, but there is, nevertheless, a basis of real achievement, and it may be worth while to review some of the successful new applications of eddy current and dielectric heating, known to all wireless experimenters as "losses" in transmitting and receiving equipment.

Eddy current heating has been employed for years in melting steels and other alloys which would suffer by contact with furnace gases, and valve manufacturers use this method for heating electrodes which would otherwise be inaccessible during the evacuation process. As the object in these cases is to secure uniform heating throughout the mass of metal, comparatively low radio frequencies or high audio frequencies are used.

As the frequency is increased there is a tendency for the current to concentrate near the surface. This is the familiar "skin effect" which increases the effective resistance of coils and conductors at radio frequencies, and it has recently been turned to good purpose for case-hardening tools, crankshaft bearings, etc., where a thin hard surface skin is required on a base of tougher temper. Older methods of case-hardening involved the heating of the whole article, the application of chemical compounds to change the constitution of the surface metal, reheating and then quenching, a succession of processes taking a considerable time and involving the possibility of blistering, non-uniform penetration of the hardening compound and surface cracking.

With radio-frequency heating the whole process is completed in a matter of seconds (four seconds for the bearing surfaces of a motor crankshaft is a typical recorded example). Since the body of the metal remains cold the article is self-quenching if the volume of surface-heated metal is a small proportion of the total volume. There is the minimum of distortion and the process is clean. Internal as well as external surfaces can be treated, and the depth of hardening is controlled by the frequency employed.

Another application of RF heating is in tinplate manufacture. To reduce the amount of tin used, electroplating has taken the place of hot dipping, but the electrodeposited surface is dull and porous, and must be re-flowed to give it a polish. In the case of the wide strip used for tin cans this is conveniently accomplished by passing the strip between coils carrying RF current.

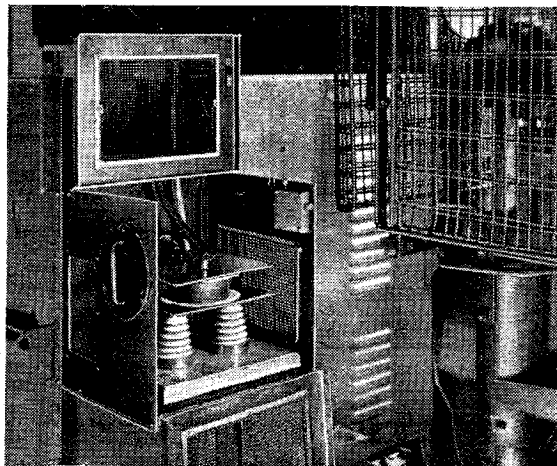

Radio heating equipment, built by Rediffusion, installed in the Development Department of I.C.I. Plastics. The heating chamber, with screening doors opened, is on the left. Discs of moulding material, seen between the electrodes, are transferred to the moulding press on the right after RF pre-heating.

As an indication of the extent to which RF induction heating is being employed in industry, it has been estimated that in America

the power already far exceeds the total used for broadcasting (about 4,000 kW).

So far we have been dealing with the heating of metallic conductors, but there is an equally important application of RF technique in heating non-conducting materials by virtue of their power factors as dielectrics.

Whereas radio frequencies are necessary to confine the heating effect to the surface in conductors, in dielectrics, where the heat is in any case generated simultaneously at all points throughout the bulk of the material, high frequencies are necessary in order to increase the heating effect when the power factor is low. The fundamental formula for the power dissipated in a dielectric is—

$$P = \frac{\omega CE^2 \cos \phi}{10^6}$$

where P = power in watts

$\omega = 2\pi \times$ frequency in c/s

E = volts (RMS) across electrodes

C = capacity in microfarads

$\cos \phi$ = power factor.

From this formula it will be seen that for a given power dissipation the voltage across the electrodes can be reduced if the frequency is increased — an important practical consideration, as it reduces the possibility of trouble from flash-over.

Best results are obtained when the block of plastic material is of regular shape and can be placed between parallel electrodes, since this ensures a uniform field and absence of local overheating. Contact between the electrodes and the material is best if it can be arranged, since spacing calls for an increase of voltage and may cause flash-over.

For most of the plastic moulding powders in common use the power factor is of the order of 0.03 and frequencies between 10 and 15 Mc/s are generally used. The power re-

Radio Heating—

quired depends on the specific heat of the material, the temperature rise required, and a number of factors which can only be found by experiment in individual cases;

In practice the weighed amount of material is pre-formed into a cake with parallel sides which is then placed between the plates of a condenser in the output circuit of the RF power oscillator. The field is

tained by probing immediately after switching off the power.

Complete screening of the heating box is obligatory to prevent radio interference, and a fine tuning control, or better still automatic frequency control, is desirable in order to compensate for changes of dielectric constant and capacity during the heating cycle.

Another industry in which radio heating may be said to have "arrived" is the manufacture of plywood. Nowadays the use of waterproof thermosetting resins as bonding media is universal, and the gluing process is a "gift" for radio heating, not only because of the time saved in getting heat to the glue lines which are embedded in poorly conducting wood, but because the RF power can be applied while the wood is under pressure. The earthed top and bottom platens of the press together form one electrode, and the "live" electrode consists of a thin metal sheet inserted in the middle of the pile of sheets. As in the case of plastic mouldings, the radio heating of plywood shows to best advantage in thick sections.

New applications of RF heating are being recorded almost daily. Removal of the last traces of water from dehydrated foodstuffs by RF heating has shown a marked improvement in keeping qualities over oven-drying methods. Articles made from transparent plastic films and the coverings of packages are being

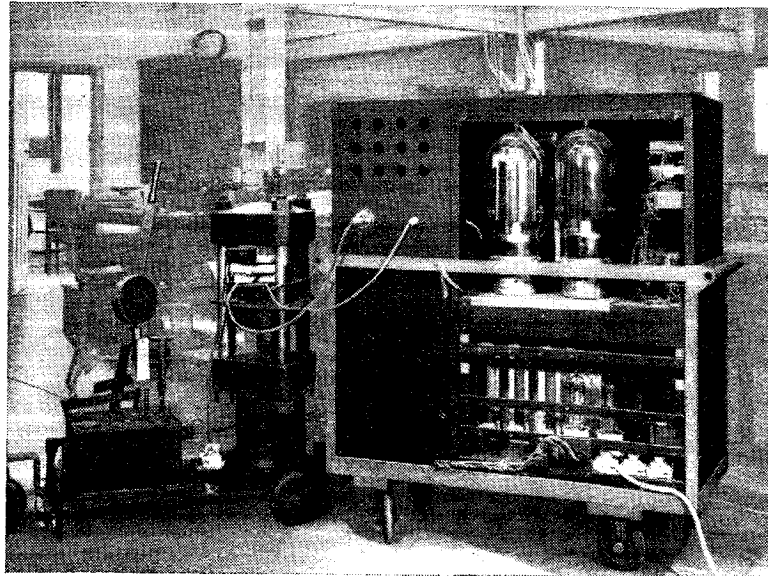

Portable experimental radio heater built by Rediffusion, with press for making laminated paper blocks. A central "live" electrode is used, with the platens of the press forming the "earthy" electrodes.

a typical rating is 2 kW per lb. for a temperature rise of 200 deg. F. in 1 minute.

Radio heating has solved a long-standing problem of the plastics industry, namely, the production of thick block mouldings. The curing of phenal-formaldehyde resins is a function of both time and temperature, and with conventional methods of moulding the outer layers in contact with the hot press are fully cured before heat has penetrated to the interior. It is for this reason that the majority of moulded articles seen on the market—ash trays, switch covers, etc.—are of thin shell-like form. Even in thin mouldings of awkward shape, trouble may be caused by insufficient local internal heating, and a radio-frequency pre-heat will not only ensure a sounder product, but can effect a saving in moulding time.

It would be ideal if the RF voltage could be applied in the press, but the difficulties of securing uniform field distribution, to say nothing of insulating one half of the press, rule out this method.

switched on for a predetermined period and the cake is then rapidly transferred to the hot mould and the press is closed. It is not necessary to "breathe" the press by opening it slightly to release the gases which arise from impurities or traces of water in the moulding powder, for these have already been driven off during the pre-heat.

Exact determination of the internal temperature presents some

Portable RF generator built by Rediffusion, suitable for laboratory work and small-scale production applications. Dimensions: 24 in. × 18 in. × 15 in. Power output, ½ kW at 10-15 Mc/s.

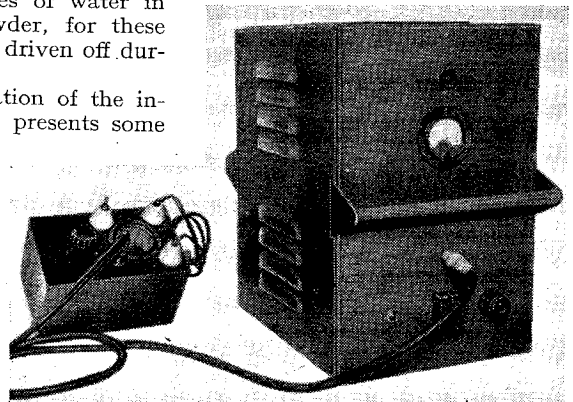

difficulty, since metallic wire thermocouples would not give accurate readings while the field was applied. However, the rate of loss of heat from the poorly conducting material is slow, and useful information can be ob-

sealed by a spot welding technique involving dielectric heating.

In conclusion mention may be made of the increasing use of diathermal heating of body tissues, one of the earliest applications of radio heating,

UNBIASED

Piped-programme Propaganda

JUST lately we don't seem to have heard much of the great "Piped Programme Project," whereby certain would-be Hitlers seek to deprive us of the freedom of the ether and force us to listen to such programmes and propaganda as they desire to pump down the electric light or telephone wiring. The promoters of this pestilential project are, however, by no means defeated, but have merely been driven underground and forced to adopt more subtle methods, owing to the firm stand in the matter taken by this journal. This is clearly shown by evidence which has recently come, by chance, into my possession.



The light fantastic toe.

It so happens that Nature in her wisdom (or lack of it) has seen fit to endow Mrs. Free Grid with an unusually large number of brothers and sisters, whose descendants seem to be constantly indulging in 21st birthday celebrations and other frivolities at which I am not unnaturally invited to be the guest of honour. Recently I had to attend no fewer than three of these affairs in a single evening. In each case a dance was being held and my interest—and later my suspicion—was aroused by the fact that at all three dances the same orchestra was pumping out its stuff from the loudspeakers, the significant fact being that the orchestra in question did not figure in the B.B.C.'s published programmes.

Investigation showed me that the music was coming in *via* the ordinary telephone lines, and I was astounded to learn on enquiring that there exist in London at present a large number of private studios equipped with first-class orchestras and several ordinary G.P.O. telephones, from which dance music is "syndicated" to private parties. Officially, no doubt, the P.M.G. has no

By FREE GRID

cognisance of this state of affairs, which is kept perfectly within the regulations that forbid tampering with the G.P.O. telephones, by the simple expedient of using ordinary telephones at the transmitting end, and placing a microphone in front of the G.P.O. earpiece at the receiving end.

I cannot for one moment doubt, however, that the whole business has the unofficial blessing of the authorities and is merely the prelude to the establishment of a "carrier current" system whereby not only dance music but also variety programmes, chamber music or anything else will be on tap from private studios for those who are prepared to pay for it.

The whole scheme is so obviously intended, by means of subtle and indirect propaganda, to prepare the public mind for a system of wired broadcasting that comment seems almost superfluous. If allowed to go on unchecked it will inevitably lead after the war to the establishment, by myself and other freedom-loving citizens, of a chain of mobile "speakeasy" broadcasting transmitters operating from planes flying well above the three-mile limit in order to keep the torch of true wireless still burning.

Alice in Blunderland

I HAVE often had to complain of the shortcomings and shortsightedness of the radio manufacturers in pre-war days, and greatly as they were deserving of my censure, they had at least the plea of youth and, therefore, lack of experience on their side. But it is otherwise with the old-established electrical industry, whose business it has had since the closing years of the last century to light and heat our homes and provide many other amenities.

It has, however, taken the war, with its urgent necessity of fuel economy and consequent obligation to be forever switching off the fires in our all-electric houses, to bring home forcibly to me the fact that the switches which control these latter devices are usually installed on the skirting board instead of the obviously convenient wrist-level position, with the result that my lumbar regions and those of thousands of other patriotic citizens have been put to severe strain by the

necessity of this constant Jack-in-the-Box bobbing up and down. Of course, I am quite aware that gas fires are controlled from a similar position, but such devices are beneath contempt.

However, it is not about this particular shortcoming of the electrical industry that I wish to speak, but of a far graver one, namely, that of lending itself to the deliberate befuddlement of the public in the matter of very great national importance. I refer to the recent experiment in which a B.B.C. official stood in the control room of a large generating station and invited us to switch off as many lighting and heating devices as we could in a period of thirty seconds in order to see what saving could be effected in the coal used by the generating station.

So far, so good, and I patriotically switched off the electric razor which I was in the midst of using in order to help in the good work, and then stood by to see how much fuel my fellow Esaus and myself had saved the nation by our praiseworthy act; it so happened that the broadcast was given at a time in the morning when the load represented by these devices was at its peak.

I suffered a severe shock when the B.B.C.'s representative who had charge of the experiment proceeded to give us the readings of a frequency meter, just as though cycles-per-second were units of power output or energy consumption. Quite apart from the utter bewilderment of us technical men, the ordinary non-technical listener would be completely befuddled by the fact that switching off lighting and other

"I suffered
a severe
shock."

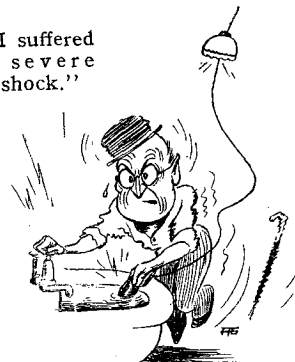

things resulted in an *increase* of what he would naturally assume to be a measurement of energy consumption. What is still worse, since the change was a mere matter of decimal points he will assume that the saving effected by switching off electric lights and fires was too small to be worth bothering about.

SIGNALS OFFICERS IN THE MAKING

Technical and Tactical Training in an O.C.T.U.

MUCH has been written, both in the specialist and lay Press, on the work and training of those who operate the complicated technical equipment of modern war, but much less has been said about those who direct such work. It is the purpose of this article to remedy that omission, so far as wireless is concerned, by giving some insight into the way an officer of the Royal Corps of Signals is produced, and incidentally, some details of his subsequent work.

To secure a clear picture of the training of potential R. Signals officers *Wireless World* was recently granted the privilege of visiting the R. Signals Officer Cadet Training Unit in the Northern Command. Here were to be found some 800 cadets who had reached various stages in the twenty-six weeks' course. During the visit the weekly "passing out" ceremony was witnessed; about twenty-five cadets, having finished their course and attained the necessary percentage of marks in the many subjects studied, received their commissions.

It should, perhaps, be emphasised that, as the Commandant of the Unit pointed out to us, the R. Signals Officer needs to be firstly an administrator and secondly a technician. It must not, however, be concluded from

this that cadets leave the Unit with little technical knowledge; the astonishing thing is that they absorb so much information on wireless and line technique in so short a time.

The time allotted for technical training is approximately 430 periods, each of three-quarters-of-an-hour duration. During this time the cadets pass through a progressive course embracing basic electricity, magnetism and AC theory, wireless and line technique and wave propagation. Of the 430 periods about 200 are allotted exclusively to wireless. In addition to the time spent in the classrooms the cadets spend many days out on "schemes," putting into practice the theory learned.

The best method of describing the technical training given to R. Signals cadets, many of whom, it should be pointed out, have not previously studied wireless or line transmission, is to outline the various sections of the course as given in the manual, *Wireless Theory*, which was prepared by the instructors and is used as a basis of the training.

The object of the method of treatment adopted in the manual is to lead the cadets, at as early a stage as possible, to an understanding of workable, though perhaps crude, circuits for both

transmitter and receiver. Subsequent steps then become a matter of detail additions to a picture already sufficiently complete for the importance of every point to be at once appreciated. Such a treatment is considered to dispel most of the "mystery" of wireless much sooner than is possible in the usual procedure, in which a laborious way is picked through variations of individual processes before completing the picture.

Before the cadet handles any of the Army sets with which he will later become familiar he must complete Parts 1 and 2 of the manual, which deal with the principles of radiation, the properties of resonant circuits, HF resistance and the valve and its functions in various stages of the transmitter and receiver.

The following two questions from those set on Parts 1 and 2 of the manual will give some idea of the standard expected from cadets—"At 1 kc/s a certain conductor has a resistance of 2 ohms and at 10 Mc/s it has a resistance of 50 ohms. To what is this due?" "A sender [the official Army term for transmitter] using MCW is tuned to 7,540 kc/s; the AF oscillator is tuned to 1,500 c/s. What are the frequencies radiated?"

Having completed the training covered by this part of the

manual the cadet is expected to handle Service sets with a reasonably intelligent understanding of their controls. He then proceeds to Part 3, which describes various other ways of obtaining oscillation, amplification, modulation and detection, and presents a more

Trainees using unit assemblies to trace the signal through the receiver.

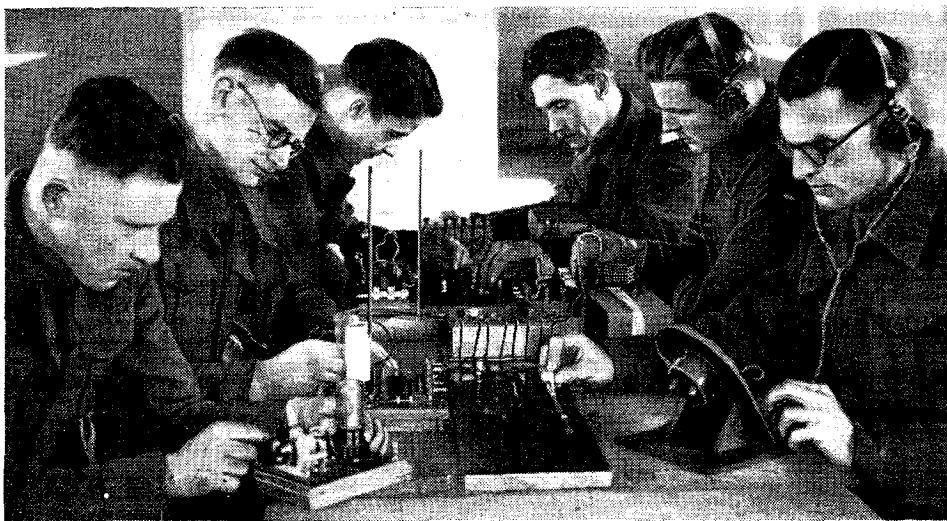

generally complete picture of the transmitter and receiver. AVC, decoupling, negative feed-back, interference, crystal control, and the principles of the superheterodyne are dealt with as fully as can be expected in the time available.

Two questions selected from those set for the examination covering Part 3 of the manual will suffice to show the knowledge of theory required.

"In the diagram [reproduced in the accompanying figure] what purpose does the resistance serve and how does it achieve it? Why

"What purpose does the resistance serve?"

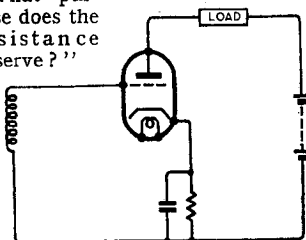

is the condenser included?" "To what extent does the use of the superheterodyne affect allocation of frequencies for use in a [military] formation and why?"

A feature of the training at the O.C.T.U. is that it is essentially a matter of practical demonstration. For example, a considerable part of the twenty-four three-quarter-hour periods spent on fault-finding, set analysis and maintenance is occupied by practical demonstrations. One block schematic diagram shows by illuminated bulbs the sections of a combined transmitter-receiver brought into use by the operation of the various controls. It is pointed out that in this way the cadet quickly learns the function of the various sections of a typical transmitter-receiver and can, therefore, more readily appreciate the purpose and action of the controls.

Another example of practical demonstration is provided by a cut-away drawing of a beam tetrode and its graphical symbol. By connecting a lead to the point on the valve symbol where an electrode is brought out to the envelope the respective electrode is illuminated on the drawing and the behaviour of the electrons in its vicinity is shown.

The usefulness of the principle of practical demonstration, as opposed to blackboard work, is most

convincingly exemplified in the method of teaching the principles underlying the operation of simple aerials and associated equipment. The importance of instructing a cadet in the fundamentals of radiation and propagation cannot be over-estimated, for it is highly probable he may be called upon to decide on the type of aerial and the frequencies to be used by his unit in the field under varying—and often difficult—conditions.

The effects produced by RF in lines and aerials being so different from those encountered in localised circuits (coils, chokes, etc.), it is to be expected the average cadet would find it difficult to visualise what is meant by such terms as "standing wave," "travelling wave," and "line resonance." It has, however, been found that by first demonstrating the effect with suitable apparatus the student readily absorbs the small amount of theory necessary to give point and continuity to the demonstration. The apparatus employed to demonstrate visibly the presence of RF in aerials depends on the use of flash lamp bulbs, which have been found more successful than meters for making visible the

effects to the assembled class.

For the cadet to be able to make full use of the knowledge of aerials gained during the course, it is imperative that he should have a good grounding in the essential facts of the ionosphere and its day and night effects on frequencies. It has been found that the best way of imparting this knowledge is to use large-scale wall diagrams showing predicted and observed critical frequencies for day and night conditions over a given period. Of course, classroom theory is one thing and the choice of the correct frequency under field conditions another; the cadets, therefore, take part in a 24-hour "scheme" to see for themselves the variation in the frequencies required during daylight and darkness.

The following questions on propagation were taken at random from those used at recent examinations: "What do you understand by 'critical angle' in connection with propagation? Why is VHF only suitable for transmission over visual distances?" "In a 24-hour service employing sky waves between two points 100 miles apart in the North of Eng-

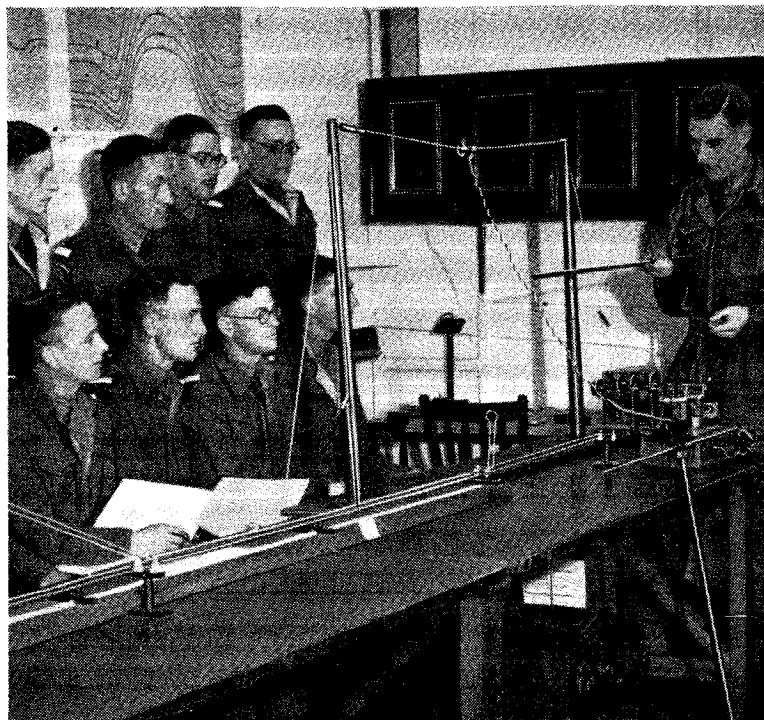

Aerial Demonstration Room. Cadets being instructed in the use of a twisted-pair feeder to a half-wave aerial.

Signals Officers in the Making— land, how many frequencies would you expect to need; what, approximately, would be their values, and which would you use at different times during the twenty-four hours? Of your operators available, one has had much more experience than the others in reading through back-

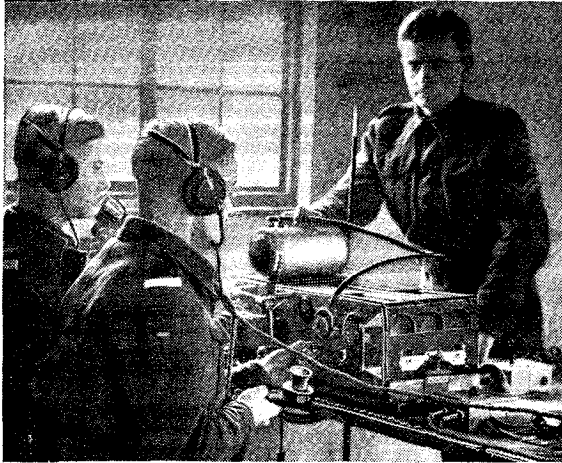

lators and a motor generator, has three stages: master oscillator, buffer and power amplifier. Training at the O.C.T.U. is not, of course, confined to wireless theory, in fact, during the course a cadet does the work of a linesman, line operator and wireless operator in addition to being fitted to undertake the duties of a signals or staff officer.

In order to give the cadet the opportunity of seeing both sides of the picture in a brigade or divisional Cadets are given every facility to become accustomed to handling Service apparatus. These two cadets are being instructed by an N.C.O. in the manipulation of the No. 19 transmitter-receiver.

ground noise; would he be most suitable during the day or night, and why?"

Cadets are given every opportunity of handling the type of apparatus likely to be met with in the field. As, however, it is possible for them to be posted to units as diverse in tactics as Comando Signals or G.H.Q. Signals it is obvious they will receive only basic details of each set. To give trainees the requisite basic knowledge standard Service sets have been "broken down" into units from which they are able to reconstruct a receiver stage by stage. To facilitate still further the understanding of "what and how," "breadboard" layouts have been constructed with which cadets trace the signal through the receiver and by means of test sockets make measurements at significant points in the circuit.

Some of the transmitters handled by the cadets are of considerable power. In some of the armoured vehicles American RCA 250-watt transmitters are installed. Another robustly built transmitter used extensively in light or unarmoured vehicles is the S12, which operates on phone, CW and MCW. The set, which operates from 230-volt mains or from two 12-volt 175 Ah accumu-

lators and a motor generator, has three stages: master oscillator, buffer and power amplifier. During the first of these he is an operator and in the second an executive officer. *Wireless World* was fortunate in being able to take part in one of these exercises. It was enlightening to travel in the armoured mobile signals office beside the 23-year-old cadet who was acting as Brigade Signals Officer. He was within a fortnight of completing the O.C.T.U. course and receiving his commission.

The vehicle in which we travelled was equipped with two No. 19 sets—one being high-powered. These transmitter-receivers, which derive their power from accumulators through a rotary converter, each combine three sets in one: (A) is the long-range set, (B) that for communication with other vehicles in the same formation, while (C) provides inter-communication for the crew.

The mobile signals office was the nerve centre of this exercise, during which the "armoured division" travelled from North Wales to the Yorkshire Moors. Wireless communication is an essential part of such an exercise, and the "Brigade Signals Officer" was elated when they were working, on phone, their base some 250 miles away.

The "attack," launched against heavy "enemy" forces, involved the use of "infantry" as well as "armoured regiments."

We have already referred to the C.O.'s statement that R. Signals officers must be first and foremost administrators. To equip the potential officer for the administrative duties, the course includes what is known as "the crowded hour." During this the cadet sits at a table equipped with a phone and the paraphernalia one would expect to find on a Brigade Signals Officer's desk. He is then bombarded with a series of messages by phone and messenger; his fellow-cadets being present to criticise his handling of the situation. The diversity of the questions with which he has to grapple efficiently and expeditiously is exemplified by the following two problems dealt with during the writer's visit:—A truck fitted with a No. 19 set having met with an accident whilst being driven to another section, where it was urgently awaited, the A.T.S. driver was injured and the set and truck damaged. It was the cadet's job to get another set to the destination, arrange medical aid for the injured driver, secure repair facilities for the truck, and arrange for the repair or, if necessary, the replacement of the damaged set. While this rather involved situation was being grappled with, Signalman Jones was ushered in with a request for compassionate posting near his home as there was nobody to look after his children whilst his wife was in hospital!

In addition to being a technician and administrator the young officer must be fully trained in "battle" tactics. The type of warfare experienced in the campaigns in the Mediterranean theatre of war has shown the necessity for this. A cadet may, of course, go through the whole of his career as a commissioned officer in R. Signals without having to climb mountains, cross rivers, wade through a bog under fire or leap streams on a swing rope, yet it is imperative that he should know his own capabilities and what he can expect of the men under his command. Ten days of the twenty-six week course are, therefore, spent at the "battle school" in the Lake District. Here the cadet undergoes one of the hardest Army stamina tests.

Final Test

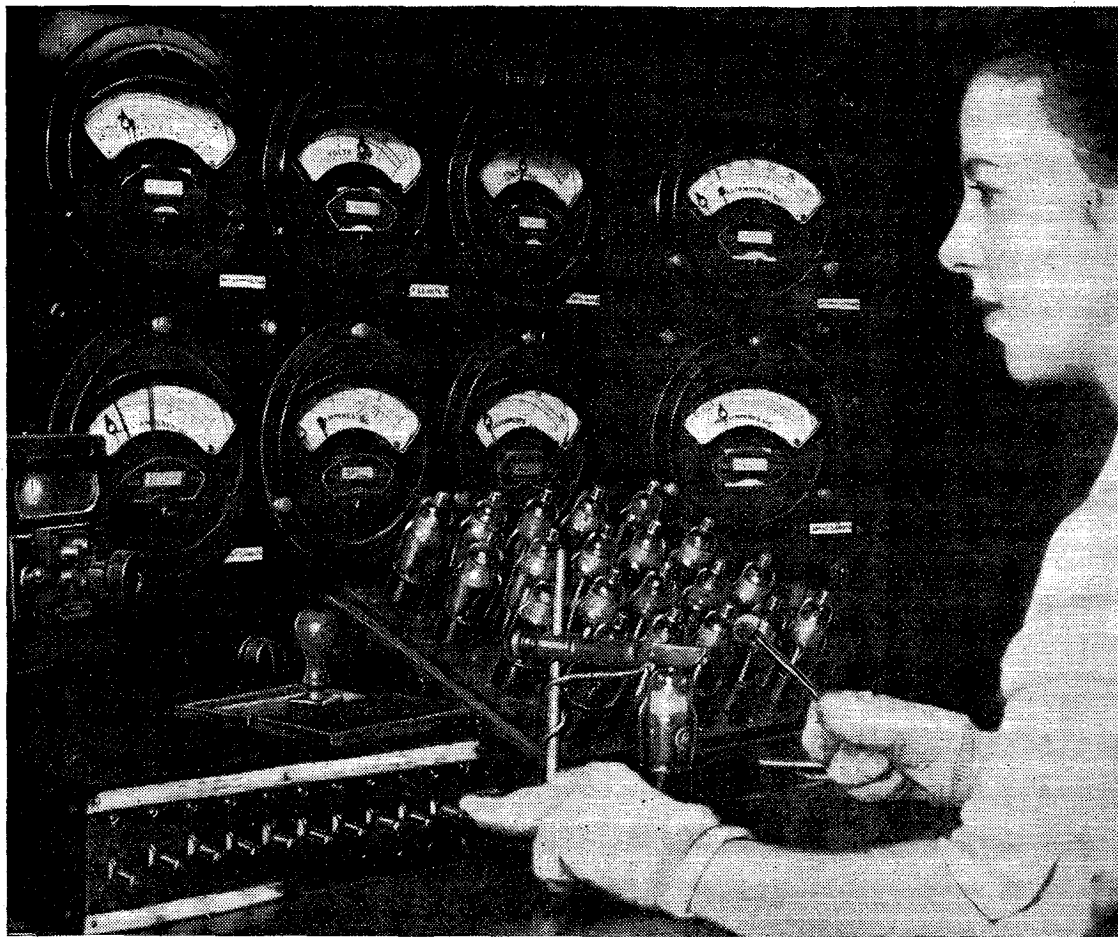

THE finished valve is finally subjected to extremely rigid tests to ensure the high quality and long life associated with Brimar products.

BRIMAR
BVA
VALVES

STANDARD TELEPHONES AND CABLES LIMITED, FOOTSCRAY, SIDCUP, KENT.

"to Insulate"

INSULATE: To separate or isolate by a non-conducting substance

Webster's Dictionary

Practically all waxes are used to "separate or isolate," but the degree of insulation provided by the different types of waxes varies enormously.

There is obviously no higher degree of insulation required than that of electrical components and apparatus in intense electrical fields, especially in the extremes of conditions to which they are subjected to-day.

We specialise in the supply of
WAXES *for all purposes—under all conditions*

Our technical advice is at your disposal.

If you have any problem of

IMPREGNATING—DIPPING—FILLING

we, as consultants to the Industry, shall be glad to offer you a solution.

CLAUD CAMPBELL & CO. LTD.

4, LLOYDS AVENUE—LONDON—E.C.3

Telephone Nos. :—ROYAL 5403/4/5.

Rotary Cutting, Filing, Grinding and Polishing—*Economy and Accuracy*

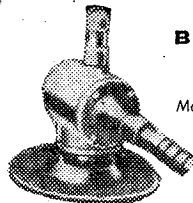
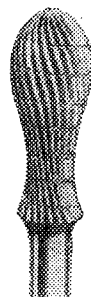
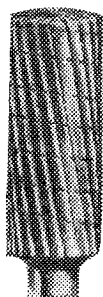
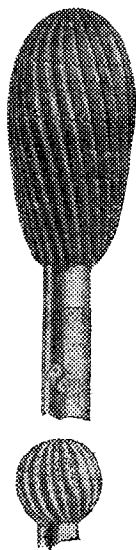

Use **MORRISFLEX** Flexible Shaft Equipment, and **REX** Rotary Files and Cutters for cutting, filing, grinding and polishing components of aluminium, Elektron, non-ferrous alloys and ferrous metals. For metal buffing and cleaning we supply **MORREX** Rotary Wire Brushes, and **MORRISFLEX** Rotary Polishing Mops and Felts, also **Felt Cones**. **MORRISFLEX** Rotary Rasps are ideal for woodworking, and attachments for **MORRISFLEX** machines include **Sanders** and **Grinders**.

MORRISFLEX machines are available in overhead suspension, bench and floor types. Their use ensures speed with accuracy, and a high degree of finish. Write for Lists.

B. O. MORRIS LTD.
 SHIRLEY,
 BIRMINGHAM.

Shirley 1237.

'Grams :
 Morrisflex, Birmingham.

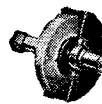
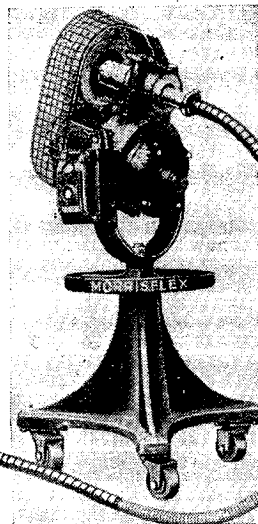

MORRISFLEX
FLEXIBLE SHAFT EQUIPMENT

MATCHING

II.—Aerial and Intervalve Couplings at Radio Frequencies

WE will now turn to the problem of matching in RF circuits. We shall, of course, be dealing very frequently with closed tuned circuits and it is as well to realise immediately that in such circuits the effective RF resistance is fixed at a given frequency, which means that maximum power is dissipated in the circuit when maximum voltage is developed across it. In other words, the matching condition for maximum power transfer is the same as for maximum voltage transfer. In addition to this requirement we may also want maximum selectivity or minimum disturbance of frequency, i.e., minimum reflected capacity in a tuned circuit. All these matching conditions may be required.

As an example let us consider the problem, a complex one, of matching the first tuned circuit of a receiver to an aerial. We want, of course, good voltage transfer, good selectivity and minimum reflected capacity.

These three factors, however, are all interdependent. Good voltage transfer can only be obtained by sacrificing selectivity, and small reflected capacity necessarily entails small voltage transfer so that the practical solution must be a compromise. The following are the features likely to be obtained in an aerial coupling circuit:—

(a) Fair voltage transfer from aerial to the tuned circuit over the whole of the received band; (b) fair selectivity over the whole of the band; (c) small capacity reflected from the aerial to the tuned circuit to enable the whole of the desired band to be covered and to permit ganging to other tuned circuits.

We will consider the most

By S. W. AMOS,
B.Sc. (Hons.)

popular of all aerial coupling circuits, the RF transformer, which is represented in its most simple form in Fig. 1(a). Now although most of what follows applies equally well to all frequencies we will assume that this aerial coupling circuit is a medium-wave one. For medium wavelengths the average receiving aerial behaves as a capacity in series with a resistance so that the electrical equivalent of Fig. 1(a) is as shown at Fig. 1(b), in which the aerial characteristics are simulated by those of the series circuit of r and C . R_S represents the RF loss of the secondary inductance L_S . Now it can be shown that the condition for maximum voltage transfer from the aerial to the secondary circuit is given by:

$$R_S = \frac{M^2 \omega^2 r}{Z_P^2}$$

where M is the mutual inductance

Remembering that $M = k\sqrt{L_P L_S}$ we have by substitution—

$$\frac{1}{k^2} \cdot \frac{L_S}{L_P} = \frac{L_S^2 \omega^2}{R_S} \cdot \frac{\omega^2 C^2 r}{1}$$

Now $\frac{L_S^2 \omega^2}{R_S}$ is the dynamic resistance R_D of the secondary circuit and $\frac{1}{\omega^2 C^2 r}$ is the aerial re-

sistance R_P considered as being in parallel with its capacitance as shown in Fig. 1(c) instead of in series with it as shown in Fig. 1(b). We thus have:—

$$\frac{1}{k^2} \cdot \frac{L_S}{L_P} = \frac{R_D}{R_P}$$

This aerial coupling circuit therefore behaves as a matching transformer and gives maximum voltage transfer when the equivalent parallel aerial resistance is accurately matched to the dynamic resistance of the secondary circuit by the expression given in formula (3) in Part I of this series. The presence of the condenser C does not affect the performance of the

transformer very much. It simply alters the resonant frequency of the secondary circuit slightly by the addition to it of some "reflected" capacity. When the circuit is

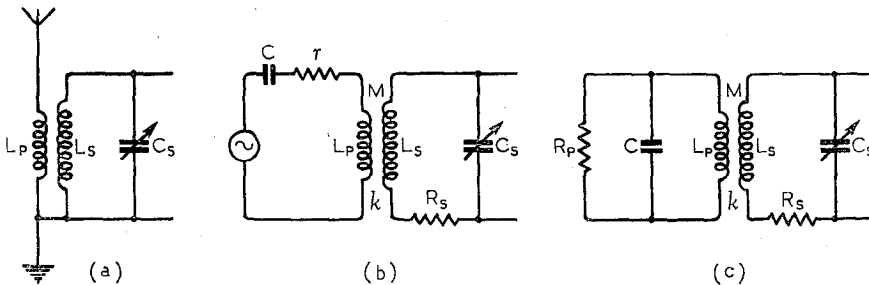

Fig. 1. Aerial coupling transformer (a) with its equivalent electrical circuit in two alternative forms, (b) and (c).

between L_P and L_S and Z_P is the impedance of the primary circuit.

Now suppose L_P to be a small primary coil of a few turns so that the primary circuit is predominantly capacitive due to the presence of C . This is equivalent to saying let the resonant frequency of the circuit CL_P be so high that the working frequency range of the secondary circuit is completely below it. If this is so we have, neglecting the resistance r in comparison with the reactance of C —

$$Z_P = \frac{1}{\omega^2 C^2}$$

accurately matched the resistance of the secondary circuit appears at the primary as equal to R_P and so the primary current is given by $\frac{E}{2R_P}$ where E is the voltage induced in the aerial. The voltage generated across the primary inductance is thus $\frac{E}{2R_P} \times R_P = \frac{E}{2}$ —so that the voltage across the secondary is $\frac{EQ}{2}$, representing an overall voltage transfer of $\frac{Q}{2}$ times. The

effective Q of the secondary circuit is thus halved when it is accurately matched to the aerial. This means that the selectivity of this circuit is 50 per cent. of the maximum possible with the coil used. This can only be achieved at one frequency, however, and by rewriting the matching equation thus:—

$$\frac{1}{k^2} \cdot \frac{L_S}{L_P} = \omega^4 L_S^2 C^2 \cdot \frac{r}{R_S}$$

we can see that the value of L_P depends on the fourth power of ω and hence on the fourth power of the frequency so that it is impossible to secure accurate matching over a wide frequency range such as the medium wave-band with a fixed value of L_P and a fixed degree of coupling k . As the frequency is varied from the value for which matching is perfect the gain falls from its maximum value of $\frac{Q}{2}$

and the selectivity increases to values greater than 50 per cent. of the maximum possible. As, in general, selectivity is considered more important than gain, this is not wholly a bad thing, provided that the variations of selectivity and gain over the received band are not too great. In circuits of this type it is usual to make $L_P = 30 \mu\text{H}$ and $k = 0.1$ where $L_S = 157 \mu\text{H}$, for which values the primary circuit is resonant at a frequency just above the upper extreme of the medium-waveband.

Suppose now the primary coil is large, so that resonance occurs at a frequency below the lowest reached by the secondary circuit. The primary circuit is now inductive for all frequencies covered by the secondary circuit and the parallel resistance of the aerial is now given by:—

$$R_P = \frac{L_P^2 \omega^2}{r}$$

and the matching equation becomes

$$\frac{1}{k^2} \cdot \frac{L_S}{L_P} = \frac{L_S^2 \omega^2}{R_S} \cdot \frac{r}{L_P^2 \omega^2}$$

$$\text{giving } \frac{1}{k^2} \cdot \frac{L_P}{L_S} = \frac{r}{R_S}$$

from which it is immediately clear that the value of L_P does not now depend on ω . In other words the large primary coil

enables matching to be secured over quite a wide range of frequencies, which means that gain and selectivity will be more or less constant over the received range. Due to several simplifications which were made in this brief analysis of the aerial coupling problem these desirable results are not quite achieved in practice. Nevertheless the large primary coupling coil does give a performance, superior as regards con-

L_S is fixed by the equation—

$$f_{\min} (\text{kc/s}) = \frac{159.2}{\sqrt{L_S (\mu\text{H}) C_S (\text{max}) (\mu\text{F})}}$$

The only variables in this circuit are thus L_P and M and by suitable choice of values for these we must obtain a reasonable performance with respect to voltage gain and selectivity. For maximum volts developed across the secondary circuit matching equation (3) applies and we have—

$$\frac{1}{k^2} \cdot \frac{L_S}{L_P} = \frac{L_S^2 \omega^2}{R_S} \cdot \frac{1}{R_a}$$

It will be convenient to restate this relationship thus—

$$k^2 L_P = \frac{R_a}{Q_S \omega}$$

Consider a medium-wave RF transformer in which $L_S = 157 \mu\text{H}$,

$$Q_S = \frac{L_S \omega}{R_S} = 50, R_a = 1$$

megohm and $\omega = 6 \times 10^8$ (equivalent to a frequency of 1,000 kc/s approximately). Sub-

stituting these values in the above expression gives—

$$k^2 L_P = \frac{1}{300} \text{ approximately,}$$

so that if $k = 1$ then L_P needs to be $3,300 \mu\text{H}$ roughly for maximum voltage transfer. When the two circuits are accurately matched the selectivity of the arrangement is, as for the aerial coupling transformer, 50 per cent. of the maximum possible. This was considered a fair performance in the case of the aerial transformer, where the maximum gain was

limited to the value of $\frac{Q_S}{2}$ of the

secondary circuit, but here, where amplification of a few hundreds of times is easily obtained, we prefer to sacrifice a little gain for the sake of increasing the selectivity. If k is reduced to one-half of its optimum value both selectivity and gain become 80 per cent. of their maximum values. This is a better compromise but we prefer to make k about one-sixth of its optimum value which makes selectivity 95 per cent. of its maximum value and gain about 40 per cent. Now instead of keeping L_P at its value of $3,300 \mu\text{H}$ and making k equal to $\frac{1}{6}$ it is more convenient to reduce L_P to $\frac{1}{36}$ of $3,300 \mu\text{H}$, i.e., about

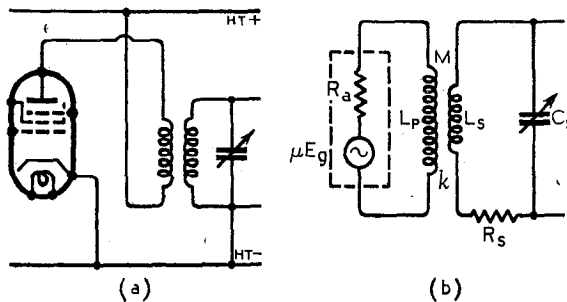

Fig. 2. An RF transformer may also be considered as a matching circuit. The circuit diagram of such a stage is given at (a) and its electrical equivalent at (b).

stancy of gain and selectivity to that given by the small primary coil. Readers desiring further details of the performance of these rival circuits are referred to some excellent articles on the subject by Sturley*. No mention has been made above of the reflected capacity due to these circuits because if they are carefully designed this is seldom larger than $25 \mu\text{F}$, which is not serious.

RF Transformers

Let us now consider a problem which has much in common with the preceding, that of matching in an RF intervalve transformer. The circuit diagram and electrical equivalent are given in Figs. 2 (a) and (b) respectively. Note that the primary resistance, R_P , is now the anode impedance R_A of the valve preceding the transformer.

In this circuit, as in that of the aerial coupling transformer, the value of C_S is fixed by the necessity of covering the desired waveband. C_S can be evaluated from the relationship—

$$\frac{f_{\max}}{f_{\min}} = \sqrt{\frac{C_S (\text{max}) + C (\text{stray})}{C_S (\text{min}) + C (\text{stray})}}$$

* K. R. Sturley. "Receiver Aerial Coupling Circuits." *Wireless Engineer*, April and May, 1941.

Matching—

90μH keeping *k* at unity. This gives precisely the same performance and means that the primary winding needs to be about two-thirds the number of turns of the secondary and wound on top of the secondary to keep the coupling as near as possible to unity.

The matching equation derived above applies only at a single frequency, but the variation of performance over the frequency range of the secondary circuit is generally small. Nevertheless it is possible, as in the case of the aerial coupling circuit, that the variation of selectivity and gain with frequency would be reduced by the use of a large primary and small coupling coefficient.

If both primary and secondary circuits are tuned, as in the case of the IF transformer, then the matching equation (3) becomes—

$$k^2 \frac{L_P}{L_S} = \frac{R_S R_P}{L_S^2 \omega^2}$$

where *R_P* is this time the RF loss in the primary winding (see Figs. 3 (a) and (b) for the circuit diagram and electrical equivalent respectively). Now both inductances and tuning capacities are fixed by the choice of the intermediate frequency and the necessity of maintaining a good *L/C* ratio. The only variable therefore is *k*, and we need to choose *k* to give the best compromise between selectivity and gain. The above matching equation is easily turned into the well-known form—

$$k = \frac{I}{\sqrt{Q_P Q_S}}$$

where *Q_P* and *Q_S* are respectively

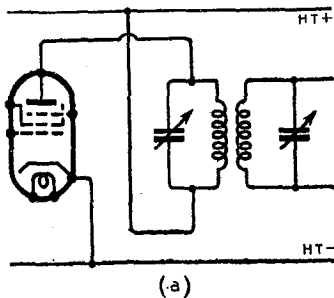

(a)

k to one-half this value we obtain, as mentioned in the last section, 80 per cent. of the maximum gain and the same percentage of the maximum selectivity and with this compromise, quite a good one, we have to be content. Typical values likely to be found in practice are *Q_P* = *Q_S* = 70, for which the value of *k* is

$$\frac{I}{2\sqrt{70 \times 70}} = \frac{I}{140} = 0.0071$$

A method of constructing IF transformers to have a particular coefficient of coupling was described by the author in a recent issue.*

Valve Input Impedance

There is a further example of matching common in RF circuits. In considering the connection between the secondary winding of an RF or IF transformer we must regard the secondary winding as a source of power and the input impedance of the succeeding valve as the load. As we are considering a case of voltage transfer equation (2) given in Part I of this article applies, and so for efficient working the input impedance of the valve must be at least ten times the dynamic resistance of the secondary winding. If the valve concerned is an RF pentode or other type of screened valve there is little difficulty in satisfying this condition at all but the very high frequencies. But if the valve is, say, a triode connected as a leaky grid detector then difficulties immediately arise. The input impedance of such a valve, due mainly to the Miller effect, de-

pend on the nature and magnitude of its anode load, but may easily be as low as 20,000 ohms

at 1,000 kc/s. Suppose the secondary circuit has *L_S* = 157 μH and *Q* = 50 at 1,000 kc/s. Then its dynamic resistance is 49,300 ohms and the effect of connecting the leaky grid detector across it is to reduce the *Q* effectively from 50 to 14. As the input resistance of a valve is roughly inversely proportional to frequency the effect of using a triode at higher frequencies than this is easily seen to be even more disastrous. The difficulty associated with this form of mis-matching can be overcome either by using a screened valve as detector, which increases the input resistance roughly a thousandfold, or by applying reaction to the triode. Reaction enables the input resistance to be controlled within very wide limits and enables the matching condition (2) to be satisfied quite easily. By means of reaction the input resistance may even be made negative, which means that the *Q* of the preceding circuit is improved, but if this process is pushed too far continuous oscillation will result.

AN EXPERIMENT IN TRAINING

ALTHOUGH merely a local arrangement, the special course in radio technology at the Oldham Technical College, arranged with the object of training youths for employment by the Admiralty as junior laboratory assistants, is of rather more than local interest.

Candidates for the course, which will last approximately 16 weeks, are under the age of 17 and up to school certificate standard in chemistry and mathematics, physics and mathematics or general science and mathematics. Training is free and students will receive an allowance of £1 or £1 17s. a week (according to age), with an additional allowance if in lodgings. Travelling expenses will also be paid.

As the course has only just commenced it is not possible to state the Admiralty establishment to which the students will be sent when they have completed the course. It is, however, known that they will be paid wages varying from £1 17s. 6d. to £2 10s. for a 42-hour week, plus a war bonus of from 5s. 6d. to 8s. 6d.

OUR COVER

A CORNER of the radio operator's compartment in a United States Navy bomber is illustrated on this month's cover. Immediately in front of the operator's head are three receivers, whilst above is the DF loop control.

the primary and secondary *Q*'s under working conditions.

This equation gives the value of *k* for maximum gain and 50 per cent. selectivity. By reducing

depends on the nature and magnitude of its anode load, but may easily be as low as 20,000 ohms

* "Calculating Coupling Coefficients" *Wireless World*, September 1943.

RADIO DATA CHARTS—14

Inductance, Capacity and Frequency: IF Range

IN the text accompanying the two preceding articles we dealt with the theory of the series and parallel tuned circuits. Let us now turn our attention to the less tractable domain of practice. What is normally required is the highest attainable dynamic resistance the formula for which is $R_D = L/Cr$. Assuming a constant ratio for L/r , for R_D to be large C must be as small as possible; hence (for a given frequency) L must be as large as possible. Simultaneously, L/r should be as large as possible and at any given frequency this also applies to $Q = \omega L/r$. The limitations to the degree to which C can be minimised are (a) self-capacity of the coil, and (b) stray wiring capacity. Let us deal very briefly in the limited space available with (a) first.

Any coil must necessarily have some capacity between adjacent turns, and these capacities will be in series with one another. At the same time there will be some capacity between each turn and the next but one—and so on. All these capacities can be represented by a single equivalent shunt capacity across the whole coil which is in parallel with the tuning capacity. To a first approximation, this equivalent capacity is independent of the length of the coil, and depends only on the coil diameter, the spacing between the turns, and the diameter of the wire. A. J. Palermo ("Distributed Capacity

By

J. McG. SOWERBY,

B.A., Grad.I.E.E.

(By permission of the Ministry of Supply)

of Single-Layer Coils," *Proc. I.R.E.* Vol. 22, July, 1934, p. 897) gives an approximate formula for the equivalent self-capacity of single layer coils. A few values of coil self-capacity have been worked out using this formula and they are given in the table. The turns of the coil should not sink into the former—as would occur if it were cylindrical and deeply threaded—or the self-capacity will be very materially increased. In any case the former will increase the self-capacity, so the values given should not be accepted as exact, but only as an indication of what may be expected.

There is still the stray wiring capacity—with which may be included valve capacity—to be considered. Even if great care is taken, it is very difficult to reduce the stray wiring capacity below about $5 \mu\mu\text{F}$, and $10 \mu\mu\text{F}$ would not be unreasonably high. The ordinary pentode has an input capacity of about $5 \mu\mu\text{F}$ more, and this increases in the very high mutual conductance television pentode as the grid/cathode spacing is less, giving a value even as high as $12 \mu\mu\text{F}$. In addition, change of bias on variable-mu pentodes produces a change in in-

put capacity which can sometimes be reduced at the expense of gain by introducing an unbypassed cathode resistor. The resistance is, however, fairly critical and depends on the valve. The change is of the order of 1 or $2 \mu\mu\text{F}$, and the correct choice of resistor may reduce it to $0.25 \mu\mu\text{F}$ or so.

Thus the total tuning capacity cannot be less than about $10 \mu\mu\text{F}$ with ordinary components in which a change of 2 or 3 per cent. may be expected with AVC bias under good conditions. Often, however, the irreducible minimum tuning capacity is more than this, and the percentage change greater. For this reason a fairly large tuning capacity is unavoidable, and is in any case desirable if AVC is used, since the change in input capacity with change in bias must be swamped by the tuning capacity. If the tuned circuit is correctly lined up with the variable-mu valve at maximum sensitivity, then increase of AVC bias will only de-tune the circuit on strong signals where precise tuning is not quite so important. From this point of view then, receivers should be ganged at low signal input.

Coil Resistance

The next point is the achievement of high Q in coils. This is by no means a simple question, and space does not allow of more than a few pointers. The key to the problem is, of course, the reduction of RF resistance of the coil which is largely due to the skin effect. At high frequencies the current tends to concentrate itself on the outside of the wire (the skin) so that the current density is not the same in all parts of the wire's cross-section. Hence the resistance to RF is greater than the DC resistance, and "Radio Data Charts," by R. T. Beatty includes several abacs for calculating the RF resistance based on S. Butterworth's work (*Experimental Wireless and the Wireless Engineer* "The Effective Resistance of Inductance Coils at Radio Frequency," Vol. III, April, p. 203; May, p. 309; July,

Diam. of coil in inches	Self-capacity in $\mu\mu\text{F}$			
	Spacing = $\frac{1}{2}$ diameter of wire	Spacing = Diameter of wire	Close-wound No. 26 SWG enamelled	Close-wound No. 16 SWG enamelled
$\frac{3}{4}$	1.73	1.26	3.95	5.85
1	2.30	1.68	5.3	7.75
$1\frac{1}{4}$	2.90	2.00	6.6	9.7
$1\frac{1}{2}$	3.45	2.50	7.9	11.7
$1\frac{3}{4}$	4.05	2.95	9.3	13.6
2	4.60	3.40	10.6	15.6
$2\frac{1}{2}$	5.75	4.20	13.2	19.4
3	6.90	5.05	15.8	23.3
$3\frac{1}{2}$	8.10	5.9	18.5	27.2
4	9.25	6.7	21.2	31.1
5	11.5	8.4	26.4	39

ABAC No. 14

[Third Series]

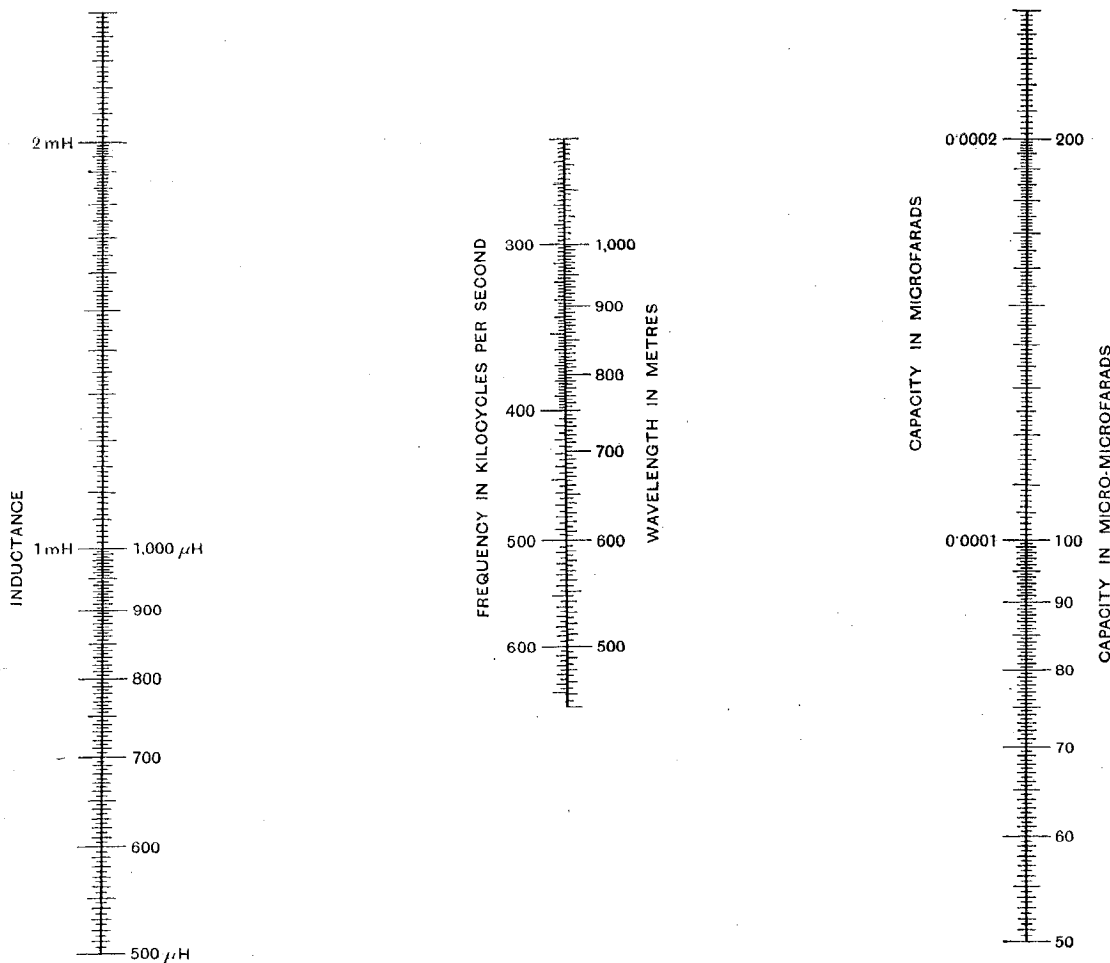

INDUCTANCE, CAPACITY AND FREQUENCY

INTERMEDIATE FREQUENCY RANGE

Wireless World
COPYRIGHT

Radio Data Charts—14—

p. 417; August, p. 483, 1926). To reduce the skin effect multi-strand wire (Litzendraht) may be used, being effective in the range 300 kc/s to 3 Mc/s. At higher and lower frequencies comparable results may be achieved with solid wire. For high Q , single layer coils should have as large a diameter as possible—but the screening can should be at least twice the diameter of the coil (for details see No. 2 of the present series, Nov., 1942). Also Q increases with increasing coil length, but only slowly when the length is equal to the diameter; and the optimum spacing between the turns is variously given as between 0.4 and 0.6 times the wire diameter. At very high frequencies it may become economical to use tubing rather than wire, and this is sometimes done in small transmitting coils.

In addition to the losses due to the RF resistance in the wire, there are the dielectric losses to be considered, and these occur anywhere where a dielectric is subjected to an electric field. Coil formers should be of reasonably low-loss material and should not absorb moisture.

An alternative method of increasing the Q of coils is the use of iron dust cores permitting the use of fewer turns of wire for a given inductance. However, since losses take place in the core the improvement is not so marked as would appear at first sight. Modern dust cores may be used with some gain in compactness at the least, up to 10 Mc/s or more (D. E. Foster and A. E. Newlon, "Measurement of Iron Cores at Radio Frequencies," *Proc. I.R.E.*, Vol. 29, p. 266, May, 1941).

There remains the question of frequency stability with change in temperature. Rise of temperature in a coil may be due to the circulating RF current—especially in oscillator circuits (see equation 10 of last month), or to general temperature rise of chassis and components due to power dissipated by resistances, valve heaters, etc. To minimise the change of inductance with temperature the coil should be very rigidly wound on a former having a low temperature coefficient of expansion, and here some of the ceramics are very useful. *In oscillator circuits

the RF current should be kept low, and here such circuits as the Franklin ("Theory and Design of Valve Oscillators," H. A. Thomas, p. 192, Chapman and Hall, 1939) can be helpful. Any residual drift may be largely compensated by means of suitable negative and/or positive temperature coefficient condensers made for the purpose. In the best equipment the methods described by W. H. F. Griffiths (*Wireless Engineer*, Vol. XIX, Jan., p. 8; Feb., p. 56; March, p. 101; April, p. 148), which treat of both inductance and capacitance compensation, may be adopted.

The Chart.—This month's chart deals with the IF range of frequencies round about 465 kc/s. The 110 kc/s range has been omitted as it is not much used nowadays. At IF it is usual to use a fairly large inductance, and a correspondingly low capacitance—of the order of 100 to 300 $\mu\mu\text{F}$ —sufficient to swamp the change of input capacity of variable- μ valves with AVC bias. This enables a fairly high dynamic resistance to be obtained with coils of only reasonable quality.

In use the chart is exactly like the preceding two, giving the required answer in one setting of the ruler. It differs only in being rather more accurate over its

limited range since the scales are not so compressed.

Example.—1 mH (1000 μH) and 120 $\mu\mu\text{F}$ resonate at 549.4 kc/s (653 metres).

"AMERICAN MIDGETS"

ALTHOUGH many American "midget" sets are in use in this country, comparatively little technical data on them has been available. Service men who are called upon to work on such sets will be interested to know that much general information on their circuit arrangement and upkeep is given in a booklet entitled "American Midgets," issued by V.E.S., 4, Melthorne Drive, Ruislip, Middlesex, at 2s. 7d. by post. Data on American G-T valves are included.

JET PROPULSION

THE official announcement of the successful adoption of jet-propulsion units for fighter aircraft has led to a big demand for the booklet "Gas Turbines and Jet Propulsion for Aircraft," by G. Geoffrey Smith, M.B.E., issued by our associated journal *Flight*. The publishers regret that owing to shortage of paper the second edition became out of print in November and a further limited reprint priced at 3s. 6d., now being issued, has been sold out before publication. Arrangements are being made for further supplies, when orders received will be dealt with in rotation. This publication, issued by Flight Publishing Company, Dorset House, Stamford Street, London, S.E.1, is the first and only book dealing exclusively with jet propulsion for aircraft, and includes early Whittle designs.

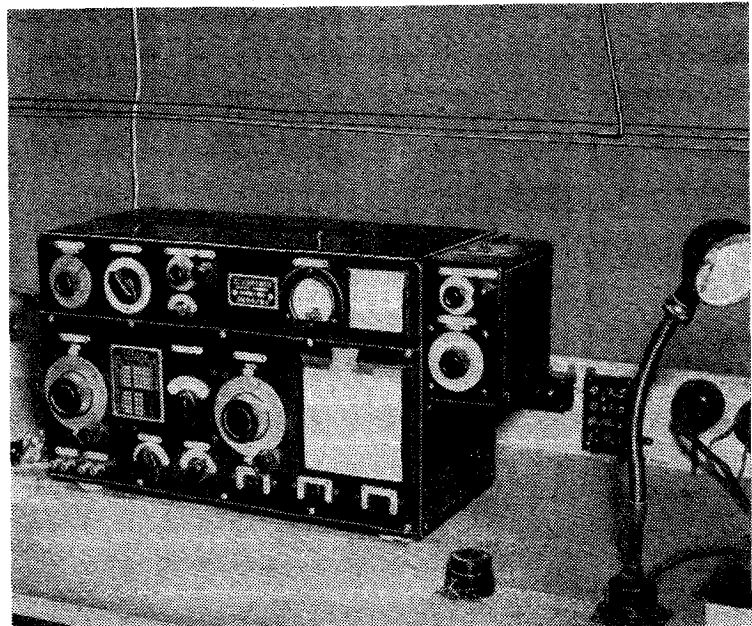

JAPANESE TRANSMITTER.—This Japanese short-wave transmitter was found by U.S. Marines at a base in the Solomon Islands.

WORLD OF WIRELESS

TELEVISION

PLEADING for the early re-start of television after the war *Wireless World* recently urged that the matter should be regarded as "a No. 1 post-war priority" and claimed that the diversion of a tiny fraction of our national resources to this task was well justified. Television should be regarded as something more than a vehicle of light entertainment, and it would be a pity to lose through niggardliness the lead established before the war.

It is, therefore, gratifying to learn (though from a report as yet lacking official confirmation) that the Government has appointed a Committee to consider and report on the future of television.

The original Television Committee, appointed by the P.M.G. in 1934, was succeeded in 1935 by an Advisory Committee charged with studying the working of the first television station; the investigation of any suggested improvements and the planning of the general development of the service. This Committee, of which J. Varley Roberts (G.P.O.) was Secretary, consisted of two representatives from each of the following: Department of Scientific and Industrial Research, B.B.C., and G.P.O. It is highly probable that the report of a "new" committee may relate in fact to an imminent renewal of the activities of this Advisory Committee.

NEW ACOUSTIC STETHOSCOPE

THE Radio Corporation of America has developed an acoustic stethoscope designed to transmit sounds originating in the body over a frequency-range of 40 to 4,000 c/s. The range of the old type stethoscopes was 200 to 1,500 c/s. Dr. Harry F. Olson, Acoustic Research Director of the R.C.A. Manufacturing Company, reports that the new stethoscope will couple the ears of the physician much more closely to the human body through the use of a reversed taper tube, which greatly improves the matching of the acoustic elements. The use of a filter in the instrument controls the frequency-range.

NEW YEAR HONOURS

AMONG the wireless personalities who figured in the New Year Honours list were A. H. Railing, chairman and general manager of the General Electric Company, who is created a Knight Bachelor; Sir Allan Powell, chairman of the Board of Governors of the B.B.C. since 1939, who is created a G.B.E.; and R. E. L. Wellington, North American Director of the B.B.C., a C.B.E.

Another member of the B.B.C. to receive recognition is John Snagge, Presentation Director, who becomes an O.B.E.

N. C. Robertson, who was recently appointed director and general works manager of E. K. Cole, becomes an M.B.E. Civil Division.

F. G. Short, senior radio officer in the Merchant Navy, becomes an M.B.E. The British Empire Medal has been awarded to A. Anderson, supervisor of an Air Ministry station in Scotland; C. A. Cleverly, civilian instructor at No. 1 R.A.F. Radio School; H. Taylor, foreman, Mullard Radio Valve Company; and R. H. Willis, a DF operator at No. 15 Group Coastal Command, R.A.F.

POST-WAR AMATEUR LICENSING

IT is learned from the annual report of the Radio Society of Great Britain that, following upon a suggestion made by the G.P.O., the Council of the Society is investigating the possibility of the City and Guilds Institute, London, establishing a special technical examination for post-war applicants for experimental transmitting licences.

This proposal is additional to that already agreed to by the G.P.O., suggesting that ex-Servicemen wishing to obtain a licence shall be exempted from examination in radio theory and/or Morse, provided they can produce evidence that during the war they served in an approved radio trade or category.

TELEVISIONS TEHRAN CONFERENCE

THE possibilities open to television were exemplified recently in America when newsreel scenes of the Churchill-Roosevelt-Stalin conferences in Teheran were transmitted from the National Broadcasting Company's television station at the top of the Empire State Building, New York, "within a few hours of their release." The films were flown by the U.S. Army Air Corps from Persia to the United States.

The transmission, which was re-broadcast by another station in Philadelphia, was received by viewers in New York, New Jersey, Connecticut and Pennsylvania.

B.B.C.'s 5,000 kW

TWENTY-ONE years ago the B.B.C.'s three transmitters had a total power of 3 kW. To-day its programmes are broadcast by well over 100 transmitters with a total power of over 5,000 kW.

SETS FOR THE BLIND

LORD WOOLTON'S Christmas Day broadcast appeal for the "Wireless for the Blind" Fund has, at the time of going to Press—when there were still some 10,000 letters to be opened—resulted in £52,500. It is anticipated the response to the appeal will exceed £60,000. The average cost of the type of receiver supplied to blind people being £10, some 6,000 blind people will this year have sets. The policy of the Fund has been to supply the most economical type of "local station" set.

It is learned from the General Secretary of the Fund that the supply of sets was very slow toward the end of last year, but, as a result of arrangements made with the Radio Manufacturers' Association and the Board of Trade, supplies should be better in future.

R.S.G.B.

THE installation of Ernest L. Gardiner, B.Sc. (G6GR), as President of the Incorporated Radio Society of Great Britain, will take place at a meeting of the Society to be held at the Institution of Electrical Engineers, London, on Saturday, January 29th, at 2.30. Following the installation Mr. Gardiner will give his presidential address; the subject being "Historical Review of Short-Wave Receivers." Visitors are invited to attend the meeting.

Stanley K. Lewer, B.Sc. (G6LJ), is the newly elected Executive Vice-President of the Society, whilst H. A. M. Clark, B.Sc. (G6OT), and A. J. H. Watson (G2YD) remain in office as Hon. Secretary and Hon. Treasurer respectively. Arthur O. Milne (G2MI) is the new Honorary Editor of the *R.S.G.B. Bulletin*.

The ordinary members of Council for the current year are F. Charman (G6CJ), D. N. Corfield, D.L.C. (Hons.) (G5CD), Wing Commander G. R. Scott Farnie (GW5FI), F. G. Hoare (G2DP), Wing Commander J. C. H. Hunter (G2ZQ), W. E. Russell (G5WP), and H. W. Stacey (G6CX).

WHAT THEY SAY

FOR twenty years our ears have been monopolised by one Corporation. . . We have shared with Russia, Germany and Italy the intellectual degradation of a monopoly of our hearing powers. "The Murmurs of an Individualist," by Sir Ernest Benn, in *Truth*.

The existing broadcasting on 200 to 500 metres should remain a B.B.C. monopoly, because only a few transmitters can be accommodated in the wave-band available;

sion Line Problems by the use of the Circle Diagram of Impedance and the Removal of a Misunderstanding Regarding the 'Correctly Terminated' Line" at the meeting of the Section on February 2nd. A discussion on "Recording and Reproduction of Sound" will be opened by G. F. Dutton, B.Sc., Ph.D., at the meeting on February 15th. Both meetings commence at 5.30.

R.S.G.B. Membership.—During the year ended September 30th, 1943, the membership of the Radio Society of Great Britain increased from 4,480 to 5,835—the highest net annual increase in the history of the Society. It is noteworthy that the total is now some 2,500 in excess of the record pre-war year.

Award by Radio.—By arrangement between the B.B.C. and a broadcasting organisation in the United States, Dr. Alexander Fleming, the discoverer of the remarkable new drug Penicillin, "received" by wireless the award of the American Pharmaceutical Manufacturing Association, presented annually to the scientist contributing most to the advancement of medicine during the year. Dr. Fleming was seated in a B.B.C. studio when he made his reply to the members of the Association assembled in New York for their annual dinner.

Any Prior Claim?—Having recently celebrated its centenary, the firm of Hulme and Son, radio and electrical manufacturers, of Derby and Belper, claim to be the first radio shop in Britain. Founded in 1843 by J. Hulme, "locksmith, blacksmith and scale maker," its interests later extended to "repairing locks, bells, safes and speaking tubes." In 1890 the business was widened to include electrical apparatus and telephones, and, in 1910, radio.

"Death Ray" Inventors.—The appeal of the inventors of the "death ray" against the convictions and fines of £50 each for alleged offences under the Wireless Telegraphy (Possession of Transmitters) Order was allowed at Lancaster Quarter Sessions. The committee upheld the appellant's submission that the words in the order "designed to be used . . ." meant "deliberately designed to be used for the purpose of a wireless transmitter. . . ."

Stalingrad Laboratory Appeal.—To help in equipping a laboratory in the rebuilt Stalingrad Hospital, the Association of Scientific Workers is organising a film show at the Cambridge Theatre, London, W.C.2, on Sunday, January 30th, at 6.30. The main feature of the programme will be "World of Plenty." Tickets, ranging from 2s. to 2s. 6d., and further details are available from the London Area Committee of the Association of Scientific Workers, 59, New Oxford Street, W.C.1.

C.B.C. Change.—Dr. J. S. Thomson is resuming his duties as President of the University of Saskatchewan, resigning his present position of general manager of the Canadian Broadcasting Corporation.

Scientific Films.—With the primary object of promoting the national and international use of scientific films in order to achieve the widest possible understanding and appreciation of scientific method and outlook, the Scientific Film Association has been formed. Enquiries should be addressed to the honorary secretary, M. Michaelis, 51, Fitzjohn's Avenue, London, N.W.3.

Brit.I.R.E.—"Some Aspects of Special Electron Tubes" is the subject of the paper to be given by F. E. Lane at the meeting of the British Institution of Radio Engineers to be held on January 27th. "A Review of Wide-Band Frequency-Modulation Technique" will be given by C. E. Tibbs at the meeting of the Institution on February 24th. Both meetings will be held at the Institution of Structural Engineers, 11, Upper Belgrave Street, London, S.W.1, at 6.30.

X-Ray Analysis.—The third Conference on "X-Ray Analysis in Industry" has been provisionally arranged to take place in Oxford on March 31st and April 1st under the auspices of the X-Ray Analysis Group of the Institute of Physics. Details will be available from Dr. H. Lipson, c/o Crystallographic Laboratory, Free School Lane, Cambridge. Although the Conference will be open to all interested, it is understood it may be necessary to limit the number of non-members of the Group for whom accommodation can be provided.

Henley's.—The appointment of S. E. Goodall, M.Sc., M.I.E.E., as assistant chief engineer of the company is announced by W. T. Henley's Telegraph Works.

Institute of Physics.—Professor J. D. Cockcroft, chairman of the Electronics Group of the Institute, will lecture on the cyclotron and betatron at the meeting of the Group to be held at the Royal Society, Burlington House, Piccadilly, London, W.1, on Thursday, February 10th, at 5.30.

Listening Schools.—It is anticipated that the number of listening schools will reach 13,000 by the end of the current school year. There were 10,829 schools registered at the beginning of the 1943-44 session, and further registrations have continued. At the end of 1943 12,112 schools were registered.

Institution of Electronics.—A meeting of the North-West Section of the Institution will be held at the Reynolds Hall, College of Technology, Manchester, at 6.30 on Friday, March 10th, when a lecture will be given by A. H. McKeag, M.Sc., on "Recent Developments in Luminescence, with particular reference to Discharge Lamps." Non-members of the Institution may obtain tickets on application to L. F. Berry, 14, Heywood Avenue, Austerlands, Oldham, Lancs.

Mentioned in Despatches.—Sgt. R. Shears, now in Royal Signals, but before the war an amateur radio transmitter (G8KW), has recently been mentioned in despatches and promoted to the rank of Lieutenant. At the outbreak of war Lt. Shears was in the service department of Invicta Radio, Ltd.

GALPINS

ELECTRICAL STORES

"FAIRVIEW,"

LONDON ROAD, WROTHAM,

KENT.

TERMS: Cash with Order. No C.O.D.

Regret Orders from Eire and Northern Ireland cannot be accepted.

AUTO-TRANSFORMER, 2,000 watts, tapped 0-110-200-220-240 volts, as new. Price **£8.10.0**, carriage paid.

RESISTANCE MATS, size 8in. by 6in., set of four. 80, 80, 150 and 690 ohms, carry $\frac{1}{2}$ to $\frac{3}{4}$ amp. Price, set of four, **5/-**, post free.

RECORDING AMPMETER, in ironclad case, meter movement wants repair, no pen, clock perfect, range 0-3 amps. Price **£5**, carr. paid.

MOTOR-DRIVEN PUMP, for oil or water, motor 220v. D.C., 1 amp., 1,250 r.p.m., maker Keith Blackman. Price **£6 10s.**, carr. paid.

200 AMP. CABLE, V.I.R., as new, rubber cover perfect, size 37/13, lengths 30 to 40 yds. Price in lengths, **5/-** per yard, carr. paid.

MASSIVE GUNMETAL WINCH, complete with long handle, for use with $\frac{1}{2}$ in. dia. wire cable, weight 50 lbs., condition as new. Price **£3**, carriage paid.

ELECTRIC LIGHT CHECK METERS, well-known makers, first-class condition, electrically guaranteed, for A.C. mains, 200/250 volts 50 cy. 1 phase 5 amp. load, **10/-** each; 10 amp. load, **12/6**, carriage 1/-.

SOLID BRASS LAMPS (wing type), one hole mounting, fitted double contact, S.B.C. holder, and 12 volt 16 watt bulb. Price **3/6** each, post free, or **30/-** per doz., carriage paid.

TUNGSTEN CONTACTS, $\frac{1}{8}$ in. dia., a pair mounted on spring blades, also two high quality pure silver contacts, $\frac{1}{8}$ in. dia., also on spring blades, fit for heavy duty, new and unused. There is enough base to remove for other work. Price, the set of four contacts, **5/-**, post free.

ROTARY CONVERTER, D.C. to A.C. Input 22 volts D.C. (twenty-two). Output 100 volts at 140 M/A, 50 cycle, single phase, ball bearing, in first-class condition, no smoothing. Price **£3**, carriage paid.

MOVING COIL AMPMETERS, 2 $\frac{1}{2}$ in. dia., panel mounting, modern type by famous makers, range 0- $\frac{1}{2}$ amp. (F.S.D. 10 M/A), price **25/-**; range 0-20 amp. (F.S.D. 20 M/A), price **30/-**.

ROTARY CONVERTER, D.C. to D.C., input 24 volts D.C., output 1,000 volts 250 M/A, choke and condenser smoothing fitted to both input and output, condition as new, weight 80 lbs. Price **£10**, carr. paid.

RESISTANCE UNITS, fireproof, size 10 x 1in. wound chrome nickel wire, resistance 2 ohms to carry 10 amps. Price **2s. 6d.** each, post free.

RESISTANCE BOX, by Sullivan, switch arm and stud type, lab. instrument, reading -1, $\frac{1}{2}$, $\frac{1}{4}$, 1, 2, 5, 10, 20, 50, 100, 200, 500, 1,000 ohms and INF, as new. **£6**.

TRANSFORMER, size 7 x 9 x 5in., 56 lbs., double wound, 230 v. to 40 volts at 1,000 watts. **£5**, carr. paid.

AMPMETER, switchboard type, 6in. dia., for AC/DC, one reading 0-300 amps., one reading 0-100 amps., either meter **50/-**, carr. paid.

VOLTMETER, switchboard type, 8in. dia., for AC/DC, reading 0-50 volts. **50/-**.

GLASS-TOPPED RELAYS, ex G.P.O., very sensitive, high-grade contacts. Magnetic. Price **15/-** each.

HORIZONTAL GALVOS, Silvertown type, 4in. dia., in good condition. **15/-** each.

FRAME-AERIAL CONSTRUCTION

Directional Reception with Standard Broadcast Sets

UNDER present conditions, reception of broadcast programmes is apt to suffer, in certain parts of the country, from interference from enemy transmitters or other sources. Much of this interference can be eliminated by using a good frame aerial, which may enable a distracting background of noise to be reduced to a worth-while extent.

Fig. 1. Showing how a frame aerial may be connected to a receiver designed for operation with a conventional "open" aerial. C₂ is a low-capacity coupling condenser.

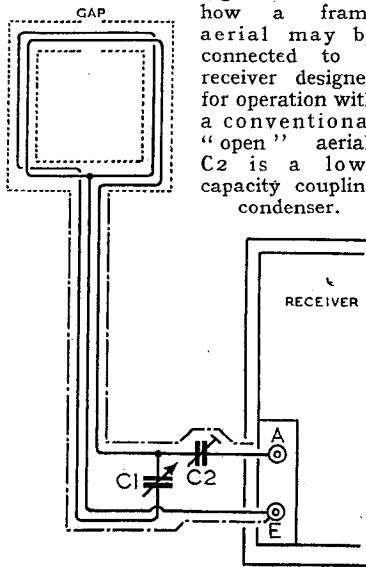

Unless precautions are taken, the signal accepted and amplified by a receiver with frame aerial may have three components, namely, the component due to the loop effect of the frame, that due to the capacity or "vertical" effect of the frame and its connections and that due to the pick-up of the signal by poorly screened circuits of the receiver itself. Rotation of the frame will have little or no effect on the two latter components, so it is necessary to eliminate them.

It is, therefore, necessary to use a receiver which is adequately screened. Its screening can be checked by setting it, with ordinary aerial, to good volume on a fairly strong transmission; then disconnect the aerial, and if the screening is adequate, signals should disappear, or at least become very faint.

By R. E. STACE,
A.M.I.E.E.

The vertical effect of the frame system can be eliminated either by completely screening the system or by using a symmetrical balanced circuit as in Fig. 1.

Further requirements for an efficient frame are (a) The receiver should have a fairly high sensitivity, as the signal pick-up of a frame is much smaller than that of an ordinary aerial. (b) The frame should be robust, and not easily deranged. (c) The circuit should be such that the frame can readily be plugged into the receiver, or replaced by the ordinary aerial, without having to modify the receiver input circuit. The practical arrangements briefly described below have been used satisfactorily by the writer.

The balanced circuit used is that shown in Fig. 1, with the centre-point connected to receiver earth, and the ends of the coil connected to a frame tuning condenser C₁. The small condenser C₂ couples the system to the aerial terminal of the receiver. This method of coupling is suitable for all normal types of receiver input circuit.

Convenient dimensions for a simple and easily constructed frame are shown in Fig. 2; these may be regarded as minimum dimensions. As signal pick-up is proportional to the area enclosed by the loop, a larger frame is obviously desirable, but it is not always convenient to find room for it. A coil of insulated wire is wound centrally and evenly round the wooden frame, with adjacent turns touching, the centre point being brought to the middle terminal CT and the ends

to the outer terminals. A total of 10 turns is suitable for this size of frame. The exact size of wire is not important; wire of 24 to 22 SWG is satisfactory. If the corners of the frame are slightly rounded, and the outer faces slightly curved, it helps to keep the turns of wire taut and in position. Provision for rotating the frame must be made, and the constructor will have little difficulty in devising something suitable from the means at his disposal.

Condensers C₁ and C₂ are mounted in a small box located close to the receiver (unless they can be mounted in the receiver itself). C₁ is of 0.0005 μ F capacity; its tuning is not very sharp, so a slow-motion dial is not essential, but it is desirable to fix a small pointer with marks, or some other means of indicating the tuning positions of a few main stations; intermediate stations can then be judged by ear. C₂ should be quite small; a few

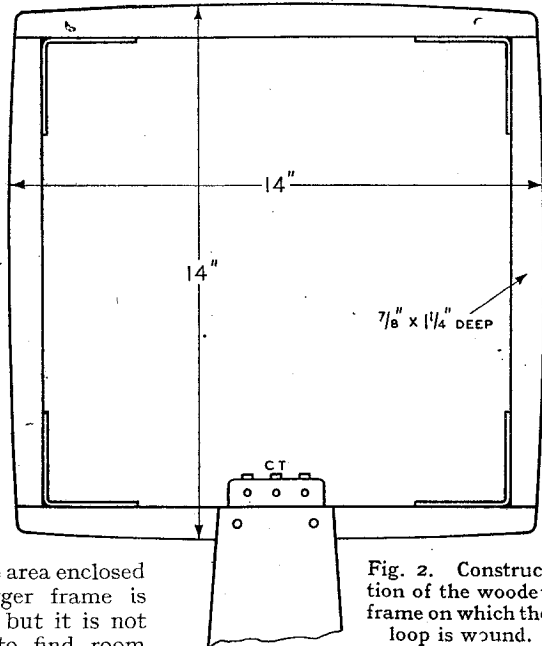

Fig. 2. Construction of the wooden frame on which the loop is wound.

micro-micro-farads will in most cases be sufficient. A small short-wave condenser or a compression type with some plates removed is suitable. Adjust this condenser by trial, reducing its

capacity as far as is consistent with adequate signal strength, and leave it set thus.

Condensers C1 and C2, together with their leads to the receiver, and the flexible leads to the frame, must be enclosed in an efficient screen earthed to the receiver, as shown by the chain-dotted lines in Fig. 1. With this balanced circuit it is not necessary to continue the screening round the coil itself (as shown by the plain dotted lines in Fig. 1), as this adds little for our purpose to practical performance.

This is fortunate, as screening of the coil is not an easy job, and materials are hard to come by at present. But if it is wished to add this refinement, distance-pieces may be fixed to the outer faces of the frame, to act as a former round which a screen of thin copper or brass sheet can be built up. Alternatively, a screen of a couple of layers of tin foil (which can be obtained from an old condenser), bound spirally with thin tinned wire, and finished with a protecting layer of tape, is satisfactory. A small gap must be left in the screen, as shown in Fig. 1. With this balanced circuit, the coil screen has little effect on the tuning of C1.

Connections to Receiver

The frame is suitable only for the medium wave-band, so it is convenient to connect it to the receiver by plugs. It can then readily be disconnected and replaced by the ordinary aerial for reception on other wave-bands, or when a stronger signal is wanted.

The position of maximum response is that in which the frame is in line with the received wave, and the zero, or minimum position, is with the frame at right angles to the wave. The zero position is much more critical than the maximum position. To reduce an unwanted signal to minimum, the frame should be set at the zero position for the unwanted signal, and not in the maximum position for the wanted signal.

A word of warning: too much must not be expected of a frame aerial. If it were possible to have a perfect frame, and if the directions of radio waves were steady and undistorted by the so-called "night" effect or other causes,

we might be able entirely to eliminate interference. But complete elimination is not usually possible in practice, and indeed a few strong transmissions seem to be little susceptible to treatment. There is also the obvious limitation that a frame is not capable of separating two transmissions if their directions at the point of reception lie in or near the same plane; the most favourable condition is, of course, when they lie at right angles.

Nevertheless, a frame can be very useful. In addition to its value for reducing distant interference, it can often be very effective in dealing with local interference. It is also useful at times in enhancing selectivity, and considerable interest attaches to its use for estimating the directions of distant transmitters.

"AUDIO-FREQUENCY GENERATOR"

WE would draw the attention of readers to some typographical errors in the mathematical expressions appearing in the article under the above title in last month's issue: Page 2, column 3, line 14, "the ratio R_3R_4 " should read, "the ratio R_3/R_4 ."

Page 2, column 3, line 10 from bottom: the expression for the frequency should be

$$f = 1 / 2\pi \sqrt{R_1 R_2 C_1 C_2}, \text{ not}$$

$$f = 1 / 2\pi \sqrt{R_1 R_2 C_1 R_2}$$

Page 3, column 1, line 4: the equation should read $Z_{AX}/Z_{BX} = R_3/R_4$, not $Z_{AX}/Z_{BX} = R_3R_4$.

THE WIRELESS INDUSTRY

A.A. TOOLS, of 197a, Whiteacre Road, Ashton-under-Lyne, Lancs, has sent us some details of the A.A. Bender. This appliance consists essentially of a powerful hand vice, on the front jaw of which can be fitted interchangeable formers for bending angles or curves, while the rear jaw carries a lever-operated bending plate. Metal sheet, strip or rod can be dealt with, and the Bender seems to have many radio applications, particularly in repair work or for making small metal chassis.

The firm of Belling and Lee has just celebrated its 21st birthday; since its beginnings as a small Founder Member of the British Broadcasting Company it has expanded in the ratio of 26 to 1 in factory space and 200 to 1 in staff.

Standard Telephones and Cables, Ltd., has taken over premises at Cambrian Chambers, 51, Broad Street, Bristol, 1. Tel.: Bristol 20613/4.



Come lovely Flowers

And so it is that from the darkness of the present hour will emerge a brighter day when the brain and brawn of modern industry will be utilised in further peacetime products and pursuits. While serving the Government to-day we are broadening both creative and manufacturing possibilities for a happier world to-morrow. Astatic engineers are available to work in co-operation with electronic engineers in the development of new wartime equipment, especially as it may have to do with pickup and transmission of sound. Astatic crystal microphones, pickups, cartridges and recording devices will be available again for your use when those brighter days are here. Register your name with our Representative for your future benefit.



THE ASTATIC CORPORATION
YOUNGSTOWN, OHIO, U.S.A.
TORONTO, CANADA.

Exclusively Represented by
Frank Heaver Ltd. Kingsley Road,
Bideford, N. Devon.

CRONAME RADIO COMPONENTS

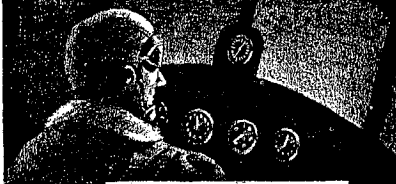

MILITARY demands on the electronics industry require large quantities of material made to precision standards never before approached by quantity production methods. Crowe has had signal success in solving problems of rapid production of precise electronics control mechanisms. This experienced ability will be an important factor in the post-war programmes of many firms.

Exclusively Represented in Great Britain by
FRANK HEAVER LTD.
Kingsley Road, Bideford, N. Devon.

CROWE NAME PLATE AND MANUFACTURING CO.
CHICAGO, ILL. U.S.A.

"Perfect" Television: Justifying 525-Line Definition

QUESTION No. 17. According to a report published in your December issue, those who propose a post-war television standard of 525 lines, interlaced scanning at 50 frames per second, imply that such a standard is sufficiently high to lead to the ultimate development of a "perfect" system. Though admitting that the proposed standard may, in practice, be good enough, it seems to me that, strictly speaking, an infinite number of lines would be necessary to achieve perfection. Will the Brains Trust explain in the simplest possible terms?

A. J. SUTHERLAND.

This question has been passed to D. A. BELL, one of the members of the Cossor research organisation which sponsored the proposed television standards to which our querist refers. Mr. Bell writes:—

WHEN I and my colleagues began to examine the possibilities for post-war television, we found two schools of thought: according to one the pre-war 405-line picture was good enough, and we ought to return to it so as to avoid delay in restarting the service; but according to the other school of thought we ought to change to a new system with "thousands" of lines to the picture, so as to make a "worth-while improvement." But is it true that thousands of lines would give a worth-while improvement in return for the greatly increased band-width they would require?

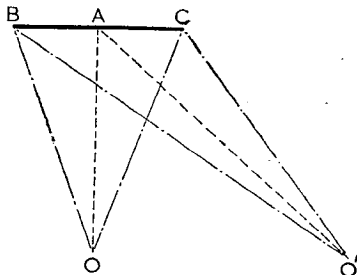

Fig. 1. Illustrating the effect of foreshortening when a television picture is viewed from the side at too short a distance.

For television purposes, a "perfect" picture is one so good that under normal viewing conditions the eye cannot detect the imper-

fections. "But," you may ask, "doesn't this depend upon the size of the received picture and the distance from which it is viewed? In a 10-inch picture, 500 lines would mean a line width of 1/50th inch, to see which one would have to look quite closely; but if some simple projection system came into use, giving a 50-inch picture, each line would be increased to 1/10th inch, which surely anyone would notice." There is, however, a serious fallacy in this argument, for it ignores the fact that the distance from which you view the picture must increase with the size of the picture. You would not sit within a yard of a 50-inch picture, to take an extreme example, because (a) the difference in distance from different parts of the picture to your eye would create a false perspective, (b) unless you were exactly opposite the centre of the picture, parts of it would appear foreshortened, and (c) you would not be able to take in the whole picture at a glance, but would have to be constantly moving your eyes to cover the screen. The first point is not very important: if you are opposite the centre of the picture at a distance of only twice the picture width, the variation in distance from your eye to different parts of the picture is less than 5 per cent. It is more serious if you move off to the side of the picture, but then the foreshortening becomes the more serious limitation. Looking from a position such as O' in Fig. 1, the apparent length of any part of the picture in the direction BC of the width of the picture would be reduced in the ratio of the cosine of the angle between the direction of viewing O'A and

the line of direct view OA; if the foreshortening is to be less than 10 per cent., the angle O'AO must not be greater than 26 deg. This means that if OO' is 2 feet, a reasonable distance for viewers seated side by side, the distance OA must be just over 4 feet; this sets a practical lower limit to the viewing distance for small pictures.

For larger pictures, the last consideration, of taking in the whole picture at once, is the governing factor. The eye moves so readily in response to one's thoughts that

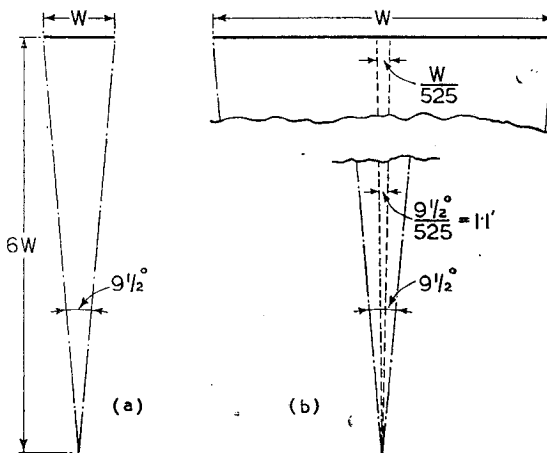

Fig. 2. Explaining why a 525-line picture should give virtually perfect definition.

one has the impression of seeing everything that lies within a very large angle in front of one, but really the field of detailed vision covered at any instant is quite small. You can test this by standing near cross-roads, concentrating your gaze on a fixed object; e.g., traffic lights on the far side, and noting how close to your direct line of vision cross traffic must approach before you can note any details of it without taking your eyes off the fixed point. Returning to the television case, it is clear that the closer you are to the picture the more you must move your eyes to follow the action, and too much movement becomes tiring; pre-war experience with television suggested that the viewing distance should be about six times the picture width, or to make this explicitly indepen-

dent of the size of the picture, the viewing angle should be $9\frac{1}{2}$ degrees (Fig. 2 (a)). If now we divide this picture into 525 lines, the angle subtended at the eye by one line width will be about 1.1 minutes (the line-width is exaggerated in Fig 2 (b)); now the resolving power of the eye (its ability to see separately two objects which are very close together) is believed to be at best between one and two minutes of angle, so the proposed picture has lines which theoretically might be just distinguishable. But the theoretical resolving power of the eye is obtained with full contrast—e.g., two black lines on a clear white ground—and no movement; so that in the practical case of a half-tone picture with movement the theoretical limit is unlikely to be reached, and there may be a slight margin of safety for those who view the picture from a shorter distance than six times its width. There is also a further margin of safety when the picture has horizontal lines and a width greater than its height; if the viewing distance is fixed by the *width*, the angle subtended at the eye by $1/525$ th of the *height* will be less than $1/525$ th of the viewing angle, so that there is a factor of safety equal to the picture width-to-height ratio.

There is then a good argument that with accurate interlacing and correct spot size a 525-line picture will give virtually perfect definition. The only obvious imperfection in the picture would then be lack of colour. Colour television must come eventually, but it must be three-colour, and definition must not be sacrificed to colour: by increasing contrasts between adjacent objects, colour tends to make definition even more critical. It follows that colour television would require just about three times the bandwidth which suffices for black and white transmission, and this could only be obtained by shifting the carrier to centimetre wavelengths; this is not yet a commercial proposition, so for a television system which could be started immediately at the end of the war we suggest a monochromatic picture with enough lines to give definition which satisfies the eye at the correct viewing distance, and we believe that 525 lines is about right.

STANDARD-FREQUENCY TRANSMISSIONS

FURTHER details are now available of the standard-frequency transmissions from WWV the station of the U.S. National Bureau of Standards. As announced recently, new 10-kW transmitters have been installed at Beltsville, Maryland, near Washington, D.C., with the result that the service has been extended and is now operated continuously throughout 24 hours.

Three standard radio frequencies are employed: 5 and 10 Mc/s continuously throughout the 24 hours, and 15 Mc/s during daylight in Washington. It has been found that, except for certain periods at night within a few hundred miles of the station, reliable reception is, in general, possible at all times throughout the United States and the North Atlantic, and fair reception over most of the world.

Each of the radio frequencies carries simultaneously two audio frequencies: 440 c/s, being the standard musical pitch correspond to A above middle C, and 4,000 c/s. In addition, there is a pulse every second heard as a faint tick lasting 0.005 second.

The audio frequencies are interrupted precisely at the hour and each five minutes thereafter for one minute during which the announcement of the station's call letters, WWV, is given in morse, except at the hour and half hour when it is by 'phone.

The accuracy of all the frequencies is one part in 10^7 , and the time interval marked by the pulse every second is accurate to 0.0001 second.

"FLIGHT" HANDBOOK

THIS manual, issued by our associated aviation journal, aims at imparting all the information necessary to give a working knowledge of the practice and theory of aeronautics. It explains, in simple terms, the design and construction of various types of aircraft, and deals with basic structural and aerodynamic principles without recourse to mathematics. Useful information on many specialised aspects of aviation is included. The new (3rd) edition, recently issued, costs 6s., or 6s. 5d. by post from *Flight* Publishing Company, Dorset House, Stamford Street, London, S.E.1.

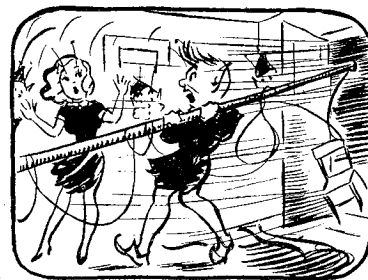

THE "FLUXITE QUINS" AT WORK

"By gosh—it's too windy up there,
Just look at the state of my hair!
I can FLUXITE this wire
Nice and warm by the fire"—
"He'll wreck us," cried OO, in despair.

See that FLUXITE is always by you — in the house — garage — workshop — wherever speedy soldering is needed. Used for over 30 years in Government works and by leading engineers and manufacturers. Of all Iron-mongers—in tins, 8d., 1/4 and 2/8.

Ask to see the FLUXITE SMALL-SPACE SOLDERING SET—compact but substantial—complete with full instructions, 7/6.

TO CYCLISTS! Your wheels will NOT keep round and true unless the spokes are tied with fine wire at the crossings AND SOLDERED. This makes a much stronger wheel. It's simple—with FLUXITE—but IMPORTANT.

The FLUXITE GUN puts FLUXITE where you want it by a simple pressure. Price 1/6, or filled, 2/6.

ALL MECHANICS WILL HAVE



FLUXITE

IT SIMPLIFIES ALL SOLDERING

Write for Book on the ART OF "SOFT" SOLDERING and for Leaflets on CASE-HARDENING STEEL and TEMPERING TOOLS with FLUXITE. Price 1d. each.

FLUXITE LTD.
(Dept. W.W.), Bermondsey Street, S.E.1.

Tape Recordings • "Tone" Arms : New Style • Scope for Hearing Aids

Alternative Recording Systems

IN answering the question, "Is Disc Recording Obsolete?", your contributor, Stuart Black, regards the film as an expensive medium for recording purposes. Taking his two points—expense of recording by the film method and expense of multiplying these films commercially—in order.

First, expense of recording. Surely it is within the realm of possibility that the big recording companies could produce disc recordings and film recordings side by side? This procedure was adopted in the early days of recording, when popular items helped to finance the recording of larger works (see H. Ridout's "Behind the Needle"), and later on, when the electrical system of recording came into being, the acoustic system was still used, so that recordings by each system were issued in the same month by one company.

Secondly, expense of reproducing copies on a commercial scale. Naturally, if ordinary film is to be used for this purpose, the expense would be high. But even before the war a system was introduced on a commercial basis which overcame this cost. I have in my possession two "Duo-trac" recordings on cellophane strip, which were on sale at 12s. 6d. each, and ran for thirty minutes. Surely, if this could be done before the war, it can be done again.

The quality of the reproduction from these tapes is a revelation, and anyone who hears these recordings must consider that any disc recording, no matter how much improved, is a retrograde step. As I see it, in one sweep the following advantages are available: (1) No needles; (2) no surface wear; (3) no limit to base response; (4) no limit to range of volume, which dispenses with the necessity for unsatisfactory volume expanders; (5) no awkward breaks in the middle of symphonies, concertos, operas, etc.; (6) constant traversal speed;

(7) high-note response limited only by the photo-electric reproducing device.

Mr. Black's point about children playing havoc with film tape is surely equally applicable to disc records. I have a collection of some 800 discs, and storage is a far bigger problem than storage of the equivalent number of film tape recordings would be. Tape can be stored easily any way up, whereas discs, for proper preservation, must be stored on edge and closely packed.

WM. H. JARVIS.

Fleetwood, Lancs.

[The "Duo-trac" system (British Ozaphane, Ltd.) was described in *Wireless World*, March 19th, 1937.—ED.]

Pick-up "Arms"

MAY I put forward a plea for the retention of the term "tone arm" to describe the tension member which prevents the pick-up from being dragged forward by the friction between needle and record? It is surely wishful thinking to give it an inert name like "carrying arm," and hope thereby to damp out torsional and other resonances (see P. G. A. H. Voigt, *Wireless World*, March, 1940, and G. A. Hay, *Wireless World*, May, 1943). No, let us be honest and call it a "tone arm," not in its original acoustic gramophone connotation but as a reminder that unless we investigate its mechanical properties with as much care as we devote to the moving-coil or armature system, it is capable of wrecking the overall characteristic of the most carefully designed pick-up assembly.

H. MORGAN.

London, S.E.

Specify the Units

ONE of the difficulties that beset the student of radio literature arises from the failure of many authors to give—together with formulæ quoted—the electrical units in which the formulæ are expressed.

I have known of more than one

learner struggling with

$$f \text{ (in kc/s)} = \frac{10^6}{2\pi\sqrt{LC}}$$

under the impression that L was to be taken in henrys and C in farads!

This formula should perhaps be well enough known, but others are not. To-day I came across this: "The effective capacitance across AB = -gL/R, g being the slope of the valve." Is g expressed in ma/V or in micro-mhos? Is L in micro-, milli- or plain henrys? And is the resultant capacitance in farads or—?

If the attention of authors could, through your pages, be drawn to this point, you would be helping considerably to clear some of the "brambles from the path of understanding."

L. HAYTER SIMMONDS.

London, S.W.15.

Incidence of Deafness

THIS Institute is frequently asked as to the numbers of deaf and deafened persons in the country and also how many are using or need hearing appliances. It is quite impossible to state definite numbers for any of these categories, but it occurs to me that the following information may be of interest to a number of your readers:—

In 1937 "An Estimate of the Incidence of Defective Hearing in England and Wales" was prepared by Arthur G. Wells, F.R.C.S., Chairman of our Medical Committee, in which, in order to give some idea of the problem of deafness, an endeavour was made to estimate, from the results of Dr. Wells' own experiences, a maximum within which various groups of persons with defective hearing would fall. This estimate indicates that of those with severe congenital hearing defect, usually known as the "deaf and dumb," there are some 32,000, whilst those whose hearing has become seriously affected by reason of disease or accident in post-natal life, and who need assistance, are probably not more than 100,000.

These figures were quoted in evidence on the deaf placed before Sir William Beveridge by this Institute in 1942.

G. W. LILBURN,

Acting Secretary.

National Institute for the Deaf,
London, W.C.1.

[The figures given for partial deafness are much lower than those of some other estimates that have been published. For instance, C. M. R. Balbi, quoting the *British Medical Journal* in *Wireless World* of May, 1942, gave 6½ millions as "a very conservative estimate" of the number of persons "having impaired hearing." He also adduced the opinion of a well-known doctor that "there were as many people in need of a hearing aid as were wearing glasses." In an I.E.E. paper, the same author gave this number as four to five millions for the United Kingdom. Another estimate, put forward at a recent I.E.E. meeting, was that there is a potential market for a million hearing aids. With regard to the "deaf and dumb," The Royal Association in Aid of the Deaf and Dumb states there are more than 6,000 of these sufferers living within its area, which comprises London, Middlesex, Surrey and Essex. That, we imagine, would imply a total of some 30,000 in the whole country; this figure agrees well with that given by Mr. Lilburn.—Ed.]

Competitive Broadcasting

AS one who is reasonably satisfied with present broadcasting arrangements, making due allowance for the unavoidable wartime absence of alternative programmes and the necessity for many recorded broadcasts, may I suggest that competitive broadcasting be avoided like the plague as being unlikely to result in any programme improvement.

Already there are occasions when the B.B.C. with its present revenue cannot afford to pay the fees required by certain artists, and if these artists' services were being competed for by an alternative organisation it is easy to see their prices would go up and possibly neither organisation would get them, or, alternatively, the effect would be that listeners would have to pay more than they do at present for the same programmes, which may or may not

be desirable from the broadcaster's point of view but cannot be said to be an improvement from the listeners' standpoint.

On the other hand, educational broadcasting from colleges and similar institutions by persons of real authority and not merely in the form of a glorified Brains Trust, would undoubtedly serve a valuable purpose.

JOHN BAGGS.

Saddleworth, Yorks.

"FOUNDATIONS OF WIRELESS"

Completely Revised 4th Edition

FOR many years this popular work has been a standard text-book for those beginning to take a serious interest in the technicalities of wireless. When "Foundations of Wireless" was first issued, the emphasis was on the reception side, and particularly on broadcast reception, but in later editions more attention has been given to other aspects. The fourth edition, just published, has been completely revised, and both transmission and reception are dealt with in right proportions for the average reader of the present day.

Although this is a "theory" book, theory is at each stage exemplified by practice, and the reader always has before him a picture of how the knowledge he is in process of acquiring may be applied in practice. Treatment may best be described as "sympathetic"; the author has the knack of seeing what points are likely to puzzle the beginner and spares no pains to help him over the stile. But it must not be suggested that this is a "wireless without tears" book, skating over the subject with the help of analogies lacking in rigorouslyness and leading at best to a superficial half-knowledge that is of questionable value. The title of this book has been well chosen; those who read it with care will acquire a really useful foundation of basic knowledge on which to build.

Treatment is non-mathematical, but algebraic formulae are freely used; they are, however, carefully explained in the preface. The book assumes no previous knowledge, and includes introductory chapters on elementary electrical notions, alternating currents and AC circuits.

"Foundations of Wireless," by M. G. Scroggie, has 350 pages and 220 diagrams and sketches. It is issued from the offices of *Wireless World* by our publishers, Iliffe & Sons Ltd., Dorset House, Stamford Street, London, S.E.1, at 7s. 6d. (by post, 7s. 10d.).

The Improved VORTEXION 50 WATT AMPLIFIER CHASSIS

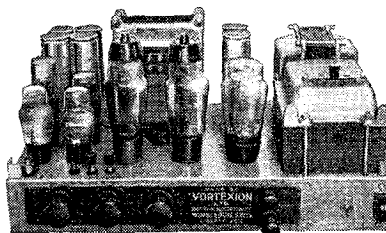

The new Vortexion 50 watt amplifier is the result of over seven years' development with valves of the 6L6 type. Every part of the circuit has been carefully developed, with the result that 50 watts is obtained after the output transformer at approximately 4% total distortion. Some idea of the efficiency of the output valves can be obtained from the fact that they draw only 60 ma. per pair no load, and 160 ma. full load anode current. Separate rectifiers are employed for anode and screen and a Westinghouse for bias.

The response curve is straight from 200 to 15,000 cycles. In the standard model the low frequency response has been purposely reduced to save damage to the speakers with which it may be used, due to excessive movement of the speech coil. Non-standard models should not be obtained unless used with special speakers loaded to three or four watts each.

A tone control is fitted, and the large eight-section output transformer is available to match, 15-60-125-250 ohms. These output lines can be matched using all sections of windings, and will deliver the full response to the loud speakers with extremely low overall harmonic distortion.

PRICE (with 807 etc. type valves) **£18.10.0**

Plus 25% War Increase

MANY HUNDREDS ALREADY IN USE

Supplied only against Government Contracts

VORTEXION LTD.

257, The Broadway, Wimbledon, S.W.19

Phone: LIBerty 2814

RANDOM RADIATIONS

By "DIALLIST"

Touching

CURIOS to find how many folk whose profession or trade is electricity in one of its many applications do not know how to touch a conductor about whose liveness there is any doubt. Of course, the best of all methods is not to touch it at all; still, there are times when we have to. Nine people out of ten will apply the fingertips. Then if it does happen to be "hot" the muscles of hand and forearm contract and next instant the hand is holding on to it with a vice-like grip. I had quite a business the other day to free a radio mechanic who was firmly and agonisingly attached to a source of 300 volts DC, for there was almost no room to squeeze past him and get at the switch. If you are in any doubt and must touch, do so with the *backs* of your fingers. The muscular contraction which closes the hand then automatically removes them from the live conductor and there cannot be any gripping.

□ □ □

Speed of Light

"FREE GRID'S" recent query about the speed of electricity seems to have caught out a good many innocent readers who do not know the depths of low cunning that he has hidden behind the bland countenance and the goggles and beneath the bowler hat. I felt rather like him the other day when, having told some of my soldiery that the frequency of middle C was 256 c/s, I asked for its wavelength. One and all made it a million and something metres. Do you know, by the way, how it was first realised that light had a speed? Observations were made on the revolution of one of Jupiter's satellites at a time when both he and the Earth were at their nearest to the sun. Six months later the Earth was in aphelion, though Jupiter was still almost as near the sun as ever, owing to the enormous size of his orbit. It was then found that the said satellite was making its coy appearance from behind the planet's disc some 16 minutes and 40 seconds late. As the Earth was then some 186,000,000 miles farther from Jupiter than it had been when the first observations were made, the only water-holding explanation was that light must take 16 minutes and 40 seconds — 1,000 seconds — to travel 186,000,000 miles. Hence the figure of 186,000 miles a second for the speed of light was the first one

produced, and it has since proved to be pretty nearly accurate.

Broken Cables

MY recent note on locating a break in a heavy multi-cored cable has brought in several suggestions from readers and more are probably on their way: in the somewhat remote part of the country where I am stationed letters may be some days in their journey. An Upminster reader tells me of an interesting method that he thought out for finding a break in the line-cord of a midget receiver. He had available a BFO and a high-gain amplifier. Over the cord was slipped a small coil, whose ends were connected to the amplifier. The BFO, set at 12 kc/s, was connected to the line cord. The output of the amplifier went to a pair of telephones. As the coil was moved along the cord signals were strong until the break was reached, when they suddenly fell off. When the outer insulation was cut at the point indicated by the coil there was found to be less than a quarter of an inch of error. My correspondent states that later tests were made with covered copper cables and that similarly satisfactory results were obtained. I must try out this tip next time a break comes my way.

Why Do They Break?

What always puzzles me not a little is why leads in stout multi-core cables that have not been subjected either to severe tension or to undue bending should break in the way they do. Take a multi-core consisting of a dozen or so leads, each lead itself being of twisted strands of

wire. You would have to pull pretty heavily to break any individual lead by brute force and by itself it will stand a vast amount of bending. But make these leads up into a cable with a heavy rubber covering and its uncertainty may sometimes be surprising. Such a cable may last for ages and seem able to stand any amount of roughish use or of reasonable bending. Or it may suddenly develop one—or more—"dis" leads when there is no history of its treatment to account for them. One of mine played me up like that only a day or two before the writing of this note. About a week previously it had been carefully reeled up and just as carefully laid in a new position. For two or three days all was well; then a fault occurred and two leads were found to be broken. There were two spare leads in the cable, so I said we would use those instead. They were connected up—and found to be fractured too! Yet none of the four showed any symptoms of being out of order when the cable was laid and it hadn't been moved since. I suppose that all must have been hanging on by single strands and that some slight movement—or even contraction due to the heavy frosts we were then having—finally severed them. All four breaks were within a 2ft. length of the cable.

□ □ □

Wartime Sets

I AM glad that the wartime set (another term, apparently, for the Utility receiver) is under way and that a fair quantity of them may be expected this year. As you know, I am no advocate of cheap wireless sets in the ordinary way. But I have seen so many homes in the past year or two in out-of-the-way spots where the old set was silent and beyond repair that I am now all for providing people who really need them with replacements

Books issued in conjunction with "Wireless World"

	Net Price	By Post
FOUNDATIONS OF WIRELESS. Fourth Edition, by M. G. Scroggie, in preparation	7/6	7/10
TELEVISION RECEIVING EQUIPMENT, by W. T. Cocking	10/6	10/10
RADIO LABORATORY HANDBOOK, by M. G. Scroggie. Second Edition	12/6	12/11
WIRELESS SERVICING MANUAL, by W. T. Cocking. Sixth Edition	7/6	7/10
HANDBOOK OF TECHNICAL INSTRUCTION FOR WIRELESS TELEGRAPHISTS, by H. M. Dowsett and L. E. Q. Walker. Seventh Edition	30/-	30/7
WIRELESS DIRECTION FINDING, by R. Keen. Third Edition	30/-	30/7
RADIO INTERFERENCE SUPPRESSION, by G. W. Ingram	5/-	5/4
LEARNING MORSE. 335th thousand	6d.	7½d.
INTRODUCTION TO VALVES, by F. E. Henderson	5/-	5/4
VALVE REPLACEMENT MANUAL, by A. C. Farnell and A. Woffenden	6/-	6/2

Obtainable from leading booksellers or by post from

LILFFE & SONS LTD., Dorset House, Stamford Street, London, S.E.1.

that will bring in the news and the entertainment that have been so badly missed. When you have lived in places where the daily papers—if they come at all—arrive in the evening and where there is hardly anything in the way of entertainment you come to appreciate the enormous amount of happiness that broadcasting has brought into people's lives. You realise, too, how much it is missed when the old set gives its last crackle and cannot be replaced. In such places the wartime receivers will be a boon—and I only hope that the bulk of them don't get swallowed up by the towns, where they aren't nearly so badly needed. From what I hear the Utility receivers will be simple, but quite useful little sets. They'll probably have nothing but a medium wave range—and why not? There's nothing much to hear on the long waves nowadays and short-wave listening is an overrated pastime with the ordinary low-priced "three-band" set. I do not suppose they will be specially beautiful and more likely than not they will not bear makers' names. But what's the odds, so long as they bring isolated homes into touch again with the news, the views and the music of the world? The great thing is that they are easy and cheap to turn out with the scanty materials and the small supply of even semi-skilled labour that is available in wartime. I take off my hat to the service-men who have worked so hard to keep worn-out ancient sets at work. But even their skill and ingenuity fails when irreplaceable valves and components go west and when sets just drop to bits through sheer old age. There is no possible chance of producing anything like enough high-grade sets to satisfy the demand, so let's give our blessing to the Utility models that may bridge the gap till peace is with us once again.

Pilfering

□ □ □

NOT a few cases of thefts of valves and other small radio parts from wireless manufacturers have come before the courts recently. When the demand is so great and the supply so short as at present there must be a temptation to employees to pocket things here and there; it's curious to note how standards of honesty are apt to alter in wartime; peacetime pillars of uprightness may become past-masters in the art of scrounging when they don khaki or blue! But this stealing of radio parts and selling them is a low-down business which every true wireless man will do his best to stamp on. Be on your guard, therefore, against anyone who lets it be known that he has ways and means of obtaining things that are normally "short."

COMMUNICATIONS DEPEND...

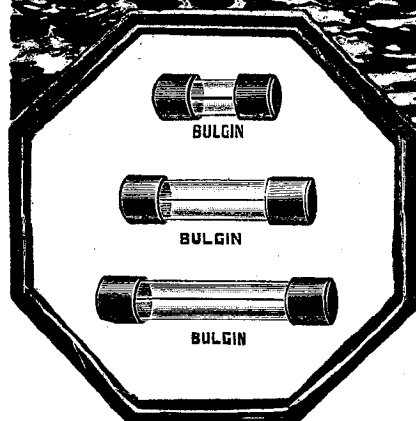
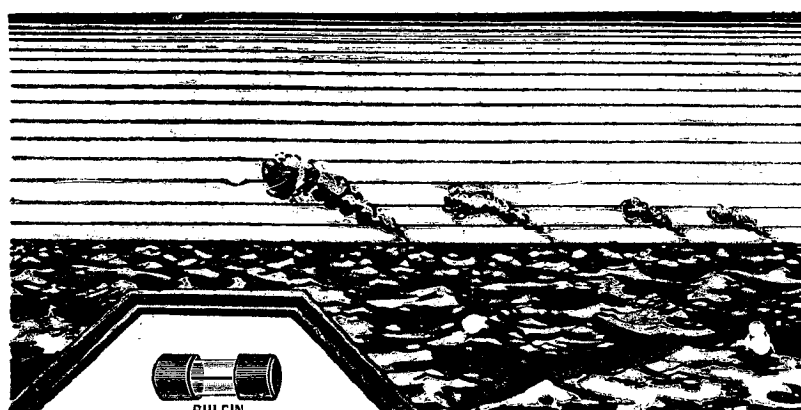

*The Choice
of Critics*

BULGIN FOR FUSES

The finest Radio and small Electrical glass-enclosed Fuses in the World. The comprehensive range, from 60 mA. to 25 A., covers every requirement. Accurate and uniform in characteristics and made to British Standard Specification No. 646, R.M.A.-, and R.C.M.F.-specification. Absolutely fireproof and safe, sure in action upon 50-75% overload.

ON SMALL PARTS...

IN countless instances quite intricate pieces of apparatus are wholly dependent on the proved reputation and reliability of their component parts.

All products from the House of Bulgin are pre-eminent for superior design and workmanship and every article bearing our Trade Mark has to pass exacting and exhaustive tests during the course of its production.

We ask the kind indulgence of the Trade on delivery until peaceful conditions return.

Please quote priority and contract No

"The Choice of Critics"

BULGIN

REGISTERED • TRADE • MARK

A. F. BULGIN & CO. LTD., BYE PASS RD., BARKING,

TEL. : RIPPLEWAY 3474 (4 lines).

ESSEX

RECENT INVENTIONS

TUNING INDICATORS

THE circuit shows an arrangement for ensuring that the voltage applied to a tuning indicator, when receiving frequency-modulated signals, is a maximum only when the circuits are correctly tuned. These are the conditions necessary for using either a high-impedance voltmeter, or a visual device of the "magic-eye" type.

The tuned output circuit L, C of the last IF stage V of the receiver is coupled through a tuned secondary L₁, C₁ to two diode rectifiers D, D₁, and a condenser C₂ is connected between the upper end of the winding L and the mid-point of the winding L₁. Each of the diodes is thus fed with voltage from both windings, that from the secondary L₁ being 90 deg. out of phase (and therefore of no effect) only

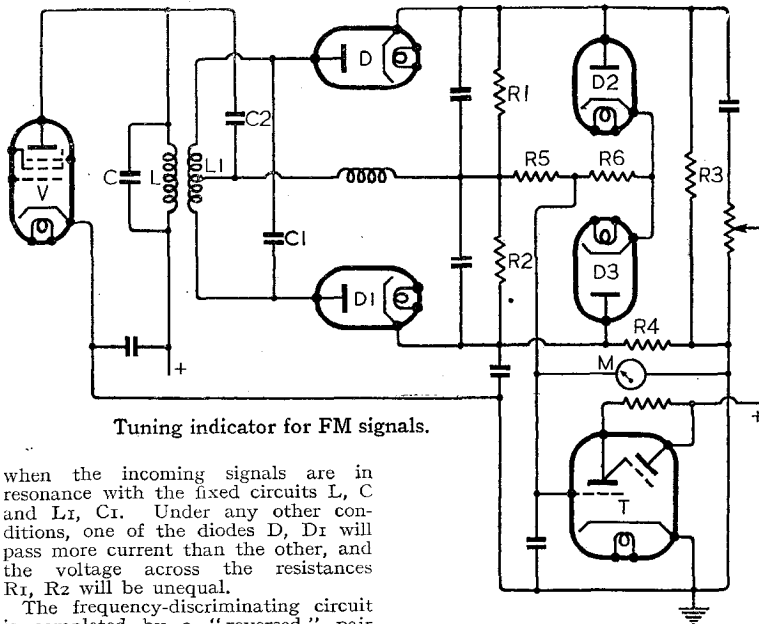

Tuning indicator for FM signals.

when the incoming signals are in resonance with the fixed circuits L, C and L₁, C₁. Under any other conditions, one of the diodes D, D₁ will pass more current than the other, and the voltage across the resistances R₁, R₂ will be unequal.

The frequency-discriminating circuit is completed by a "reversed" pair of diodes D₂, D₃, which are coupled to the first pair through resistances R₅, R₆, and are balanced by resistances R₃, R₄ equal to R₁, R₂. Except at resonance, one of the diodes D₂, D₃ will conduct and cut off the other, thus lessening the effective voltage applied either to a voltmeter M, or, alternatively, to an indicator T of the cathode-ray type.

The British Thomson-Houston Co., Ltd. Convention date (U.S.A.) February 12th, 1941. No. 554388.

"MUTING" FM RECEIVERS

IT is known that frequency-modulated signals give a high signal-to-noise ratio, once the incoming signal exceeds a certain threshold strength, this being due in large measure to the action of the amplitude-limiter which forms part of the receiving circuit. Actually, so long as a worthwhile signal is present, the limiter is effective in shutting out undesirable background "noise" from the receiver, but when tuning between

A Selection of the More Interesting Radio Developments

stations the inter-channel noise may be very severe.

In order to overcome this difficulty, the "noise" voltages which occur naturally in the limiter during the times when no signal—or only a weak signal—is being received are detected and utilised to develop a bias which serves to block one of the amplifying stages, and so silences the loudspeaker.

The British Thomson-Houston Co., Ltd. Convention date (U.S.A.) August 20th, 1941. No. 555403.

crystals, and so produces a "blocking layer" of high efficiency. The layer is finally sprayed or covered with a metallic coating to form an outer electrode.

The British Thomson-Houston Co., Ltd. Convention date (U.S.A.) December 18th, 1941. No. 554822.

WAVE GUIDES

THE transmission, without appreciable loss, of ultra-short-wave energy from point to point through a hollow conduit or wave guide depends upon a certain fixed ratio being maintained between the dimension of the conduit and the wave to be transmitted. In the case of a rectangular conduit, the longer diameter is the more critical dimension of the two, and should not vary for a given wavelength.

It may be desired, in practice, to be able to alter the "run" of the conduit, so as to change the direction of travel of the wave, without introducing any sharp corners. For this purpose the inventors make a rectangular conduit in two sections which are joined along their length by external flanges on each section. Fairly deep, transverse grooves are formed at regular intervals on one or both of the sections, and project outside the conduit (so as not to cause reflections of the internal energy). These give the wave guide sufficient flexibility to allow it to be bent gradually in both planes, or to be twisted about the axis, without causing attenuation.

British Insulated Cables, Ltd., and J. C. Quayle. Application date July 10th, 1941. No. 555194.

RF TRIODE AMPLIFIER

THE anode and control grid of a three-electrode valve, suitable for handling very high frequencies, are arranged on opposite sides of a central "openwork" cathode structure consisting of a number of parallel wires which are coated either with a photo-sensitive or an electron-emissive substance, only on the side facing the control grid. The anode and control grid both consist of a plane disc, which, together with the connecting lead, may form the inner conductors of coaxial transmission lines, carrying the input and output currents respectively.

The cathode wires are strung across a window or aperture formed in the middle of a metallic plate, which is sealed into the walls of the tube so as to divide it into two mutually screened sections. A large "standing" anode current is avoided, in part by the one-sided emissivity of the cathode wires, and in part by the use of an auxiliary grid arranged between the anode and the earthed cathode structure.

G. Liebmann and Cathodeon, Ltd. Application date November 20th, 1941. No. 555478.

SELENIUM RECTIFIERS

THE performance of the dry-contact type of rectifier depends upon the action of the so-called "blocking layer," which possesses a much higher electrical resistance in one direction than the other.

In manufacture a disc or block, say, of aluminium is first coated with a thin layer of bismuth in order to ensure a good contact between the base and the selenium, which is usually deposited by vaporisation, preferably in three separate layers. A small percentage of chlorine may be added to the first two layers, to reduce their overall resistance. The deposition of each layer is followed by a period of heating or "cooking."

According to the invention, the last layer is sprayed with a one-per-cent. solution of hydrogen peroxide in pure water. This forms a thin coating of selenium dioxide, which extends around and between the adjacent

The British abstracts published here are prepared with the permission of the Controller of H.M. Stationery Office, from specifications obtainable at the Patent Office, 25, Southampton Buildings, London, W.C.2, price 1/- each.



Magnets

He earns no medals; his name will never make headlines; his way of life is modest and his work unexciting.

But to us he is an individual, a personality; not just a number on the time clock. He is a skilled man — and more, because for years his skill has been allied to the Philips tradition of doing things more efficiently; of making things just that much better.

He melts metals—very special metals which are used for making 'Ticonal'* permanent magnets of unusual power and unique properties; an outstanding Philips' invention. He is one of the thousands of Philips workpeople who gave you, before the war, the Philips products you knew and trusted so well. His skill is a vital asset to the nation today.

* Registered Trade Mark.

PHILIPS



RADIO ★ LAMPS

AND ALLIED ELECTRICAL PRODUCTS

PHILIPS LAMPS LTD., CENTURY HOUSE, SHAFTESBURY AVENUE, W.C.2 (24F)



GRAMPIAN

'SOUND IN SOUND'

- ★ SPEAKERS
- ★ AMPLIFIERS
- ★ MICROPHONES

WHEN HAPPY DAYS ARE HERE AGAIN

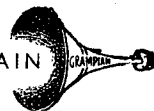

GRAMPIAN REPRODUCERS LTD. HAMPTON ROAD, HANWORTH, MIDDLESEX.

Telephone: FELtham 2657-8

M·O·R·S·E

COMPLETE PRACTICE UNIT

as supplied to many branches of H.M. Services

No. 1261. Complete Morse Practice Unit. Heavy commercial Key with nickel silver contacts and sensitive triple adjustment. High-tone Buzzer with silver contacts, mounted on bakelite base with cover. Battery Holder, complete with 4.5 Ever

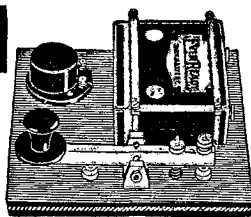

Ready battery. All metal parts heavily nickel plated, and the whole mtd. on polished Mahogany Base, 6 1/2 in. x 9 1/2 in. Price **29/6**

Send Id. stamp for Illustrated List
SIGNALLING EQUIPMENT LTD. (Dept. 8)
 Merit House, Southgate Road, Potters Bar. Phone: Potters Bar 3133

It isn't isn't what ?
 Isn't a watt !
 It's the c.g.s. unit of energy.

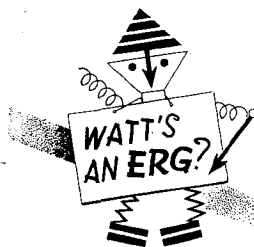

WHAT'S "ERG" ?
 ERG is the trade mark identifying a line of products that will be available when we've finished the biggest job of all.

ERG RESISTORS LTD.

1021a, FINCHLEY ROAD, LONDON, N.W.11
 PHONE: SPEEDWELL 6967



FOR THE RADIO SERVICEMAN DEALER AND OWNER

The man who enrolls for an I.C.S. Radio Course learns radio thoroughly, completely, practically. When he earns his Diploma, he will KNOW radio. We are not content merely to teach the principles of radio, we want to show our students how to apply that training in practical, every-day radio service work. We train them to be *successful!*

Special terms for members of H.M. Forces.

.....You may use this Coupon.....

INTERNATIONAL CORRESPONDENCE SCHOOLS Ltd.
 DEPT. 38, INTERNATIONAL BUILDINGS, KINGSWAY, LONDON, W.C.2

Please explain fully about your Instruction in the subject marked X
 Complete Radio Engineering. Radio Service Engineers.
 Elementary Radio. Television.

And the following Radio Examinations :-
 British Institution of Radio Engineers.
 P.M.G. Certificates for Wireless Operators.
 Provisional Certificate in Radio Telephony and Telegraphy for Aircraft.
 City and Guilds Telecommunications.
 Wireless Operator and Wireless Mechanic, R.A.F.

Name..... Age.....
 Address.....

A GOOD MATCH FOR TODAY'S SPECIFICATIONS

...plus a few items for which specifications have not yet been written

ELECTROLYTIC CONDENSERS—All capacity and voltage ratings and combinations.

PAPER DIELECTRIC CONDENSERS—Wax- or oil-impregnated sections in potted or oil-filled containers, A.C. and D.C.

MICA DIELECTRIC CONDENSERS—Low and intermediate voltage molded types.

RADIO NOISE-SUPPRESSION FILTERS

HIGH-VOLTAGE NETWORKS

KOOLOHM RESISTORS

SPRAGUE CAPACITORS

SPRAGUE SPECIALTIES CO.
 North Adams, Mass., U.S.A.
 103 Grove End Gardens, London, N.W. 8

QUALITY COMPONENTS • EXPERTLY ENGINEERED • COMPETENTLY PRODUCED

CLASSIFIED ADVERTISEMENTS. Rate 6/- for 2 lines or less and 3/- for every additional line or part thereof, average lines 5-6 words. Each paragraph charged separately. Press Day: March issue, first post Friday, February 11th, one day earlier at branch offices. Box Numbers 2 words, plus 1-. Deposit System: particulars on request. No responsibility accepted for errors.

Ode

Partridge

No. 29

Thanks

Designers of our ships and planes
We give you hearty thanks,
To merchant seamen, miners, too,
And those who built our tanks.

Without the help of factory hands,
Civil Defence, Home Guard,
The Nurses, Waafs, the Aps and Wrens,
Life would be very hard.

Thanks to the Army and Marines,
Thanks to the King's Nav-ee
And Air Force lads, we thank you for
The fruits of Victor-ee.

We're told these fruits will soon be here.
Lemons from Sicil-ee,
We've often wondered what they're
like
Now we can suck and see.

N. Partridge

Transformer Manufacturers,
76-78, PETTY FRANCE, LONDON,
S.W.1. Telephone: ABBey 2244.

NEW RECEIVERS AND AMPLIFIERS

30-WATT ac amplifiers, precision built instruments, input and output channels to requirements; early deliveries.—Below.
150-WATT racks, comprising 5 amplifiers as above intercoupled, fitted for remote control for industrial installations; send for full details and illustrations; complete equipment, including speakers and microphones, etc., available.—Below.

18-WATT ac/dc amplifiers, mixing input channels, bass and treble controls, input and output transformers; 18gs.—Below.

DANCE and stage transportable equipment, comprising 18-watt amplifier as above, m/c mike, adj. stand, 2 speakers, cables; 36gsn.—Broadcast & Acoustic Equipment Co., Ltd., Broadcast House, Tombland, Norwich, 26970.
£24 only.—New 7-valve "Wireless World" quality amplifier with tone control stage, 8 watts push-pull trade output, price includes super quality triple cone, 12in permanent magnet speaker with large matched output transformer and all valves; as above but with 15-watt tetrode output, £25, ideal for realistic reproduction for public address, limited number available.—Bakers Selhurst Radio, 75, Sussex Rd., S. Croydon.

RECEIVERS, AMPLIFIERS—SECOND-HAND
PREMIER 4-watt ac amplifier, with valves and 7in spkr.; 90/- offer.—Box 3031.

W.W. 2 R.F. tuner and 1 P.P. amplifier; "W.21.—Starr, "Fairfield," Sandford Mill Rd., Cheltenham, [2398]

W.W. Q.A. super receiver, 4 wave-band, all valves, brand new, alum. chassis; offers.—Elson, 7, Broadgates Ave., Beeston, Notts.

W.W. 2RF set; 3½w QA; W.W. Bandsread s.w. converter, all in cabinet, £17/10; Wharfedale Golden speaker, infinite baffle, £4/10.—9, Willett Close, Petts Wood, Kent.

2 only, Philips 11-valve television chassis, including scanning coils, no valves, new, contains 100s of useful components, £12/10 each; Rothermel Senior crystal gram pick-ups, 77/6; Mazda CRM91 9in cathode ray tubes, 6gsn; good range of American GP and UX valves.—H. P. Radio Services, 55, County Rd., Liverpool, 4. Tel. Aintree 1445. (Est. 1935.)

G.E.C. Radiogram, ac/dc, exchange communication receiver, cash adjustment.—Boston, 23, Coventry Rd., Nuneston, Works. [2399]

TRI-CHANNEL Paraphase 6v, Q amplifier, Magnavox 66, £20; Collaro record changer, £25; ac/dc Taylormeter 83a, offers; 0-200 mc, ma meter, £1; spare valves, etc.—Box 3034. [2381]

R.M.E. 69 poise silencer, perfect; best offer.—Box 3035. [2380]

7 Battery amplifiers for microphone and gramophone, stages HL2, LP2, and class "B" PD220A, offered, £7/10; 1 3 watt ac/dc, 200/250 volts amplifier, carbon microphone and speaker, £9; 1 8 watt ac/dc, 200/250 volts amplifier, 2 speakers, gramophone and microphone plugs, no microphone, £10; aerial equipment, 40/36, 6in/m, 25/- per 100 yds; copper earth rods, solid, 12in 1/6, 18in 2/-; stand-off bracket, 1/6; carriage extra; cash with order.—Larg's, Whitehall Street, Dundee. [2344]

Wanted

WANTED, small modern portable radio.—David McMaster, Bures, Suffolk. [2337]

WANTED, receiver unit, Lowther, A.D.T., or Haynes R.2 or pretuned Quality receiver.—Box 3024. [2334]

WE offer cash for good modern communication and all-wave receivers.—A.C.S. Radio, 44, Widmore Rd., Bromley. [1541]

HALLICRAFTERS SX25 or SX28 receiver urgently required, with matched speaker; high price given for perfect instrument.—Box 2998. [2247]

LONDON CENTRAL RADIO STORES will pay good prices for receivers, radiograms, amplifiers, dynamos, converters, test equipment, electric gramophone motors, and all radio and electrical accessories.—London Central Radio Stores, 23, Lisle St., London, W.C.2. Gerrard 2969. [9836]

HIGH price will be paid for modern high-performance communications receiver incorporating 2 R.F. stages and "R" (db) meter, with full band spread, coverage, complete with matched speaker, servicing manual, etc., all in perfect working order and condition; internally lighted dials preferred.—Box 2999. [2248]

NEW LOUDSPEAKERS

BROADCAST 12in p.m. loud speakers, precision built instruments to lab. standards and micrometer accuracy. Ticonal magnets, demountable diaphragm and magnet assemblies, perfect and permanent alignment, extended frequency range, uniform response, superior acoustical characteristics, maximum sensitivity, highest efficiency.—Broadcast & Acoustic Equipment Co., Ltd., Tombland, Norwich, 26970. [2025]

Advertisers and buyers are reminded that under Defence Regulations 1939, Statutory Rules and Orders 1940, Number 1689, a permit (T 99 G) must be obtained before sale or purchase of certain electrical and wireless apparatus, particularly such valves and apparatus as are applicable to wireless transmission.

SEXTON'S for RADIO SERVICE

ELECTRIC SMOOTHING IRONS, for 100/110 volt, 200/220 volt, 230/250 volt AC/DC mains, 3-3½lb. weight, strong wooden handle, with plated thumb rest, dome, connector guard and rest, ground and polished sole plate, complete with 6ft. 3 core flex at 28/6 each, including Purchase Tax and postage. Please state voltage when ordering. Limited quantity available.

WHY NOT BUILD YOUR OWN RADIO RECEIVER? A Four-Valve Universal Mains Medium Wave radio can be easily constructed at home from many of the odd components that you as a radio enthusiast will undoubtedly have, or which are readily obtainable from practically any radio dealer. We offer to you comprehensive instructions at 5/- per set, which contains theoretical circuit, point to point wiring diagram, component layout and list of the components with the correct specified values that are necessary to build "The VICTORY UNIVERSAL FOUR." Frankly you will be amazed at the performance of this midget radio when comparing with the high price sets at present on the market.

BRIVARON BRITISH MADE VALVES. American types: 80, 5Y3, 5Y4, 5 volt rectifiers, RF.120 4 volt rectifier, type RF.30 equivalent to 1D5, URIC at 11/- each.
HAND CRYSTAL MICROPHONES, with 7ft. screened cable, manufactured by Brush Crystal Co., Ltd., at £3.3s. each.
GOODMAN'S 3½IN. P.M. SPEAKERS, 12 ohms voice coil, ideal for microphones, communication sets at 30/- each.
TERMS: Cash with Order only. Send 1d. stamp and S.A.E. for list of appliances, valves, etc.

J. E. SEXTON & CO. LTD.
164, Gray's Inn Road, London, W.C.1.
Tel: Terminus 1304 & 4842.

ARMSTRONG SERVICE

OUR SERVICE DEPARTMENT IS STILL AT YOUR SERVICE

ARMSTRONG MANUFACTURING CO.
WALTERS ROAD, HOLLOWAY, LONDON, N.7
Phone: NORTH 3213

L.R.S. STUART PUMPS

As supplied to Govt. Depts. & County Councils.

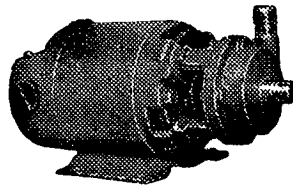

These Centrifugal Pumps are ideal for Machine Tool Cooling and all pumping purposes—hot or cold water. Supplied complete with foot-valve, strainer and hose union. Suitable rubber hose available from stock.

No. 10. 100 gals. per hour. Carr. 2/- extra. £5 2 6
No. 11. 280 gals. per hour. Carr. 2/- extra. £6 6 0
No. 12. 500 gals. per hour. Carr. 3/- extra. £7 12 0

Please send 2½d. stamp for specification. State purpose for which pump is required.

The **STUART AUTOMATIC FLOAT SWITCH** is the best method of controlling water. Post paid level. Price complete with all fittings.... £2 6 0

LONDON RADIO SUPPLY CO.
Estab. 1925
Ardingly Road, Balcombe, Sussex

THE RADIO INSTRUMENT CO.

A varied range of Mains and Output Transformers now available.
RECEIVER REPLACEMENTS, 350 v., 100 m.a., 26/6.
RADIOGRAMS AND AMPLIFIERS, 350 v., 120 m.a., 37/6.
SPECIAL EQUIPMENT, 500 v., 150 m.a., 41/6.
 The above can be supplied with 4 v. or 5 v. and 6 v. L.T.s.
 Type W.V. mains trans. to specification for the "WIRELESS WORLD QUALITY AMPLIFIER," 45/-
OUTPUT TRANSFORMER (OP12) 50 watts.
 A multi-ratio unit, primary current 150 m.a., 120 hrv. inductance, tapping primary, multiple secondaries, for triodes or pentodes, matching any speaker combination and impedance. Single valve or push-pull, class A, AB, AB2, 42/6.
32 watt AMPLIFIER KIT.
 A range of components selected from stock for building a 32-watt amplifier using 6L6 or 807 types of valves in Push-Pull AB2 with negative feedback.
 Comprising:—500 v. mains transformer, OP12 output trans., 120 m.a. smoothing choke, volume control, resistors and bias condensers, tubulars and mica mounted on terminal boards. Valve sockets and accessories. With circuit diagram, 48. (For details see below).
"SUGGESTIONS FOR AMPLIFIERS."
 To assist the users of our components, we have prepared some data sheets, giving circuit diagrams and information on the construction of amplifiers with outputs of 12, 32 and 50 watts. The sheets, together with technical data and specifications of all our components, full description and circuit of the 32-watt amplifier kit are available on application.
 (Restrictions enforce a charge of 6d. for this literature.)
 (Components catalogue and code chart for transformers 2½d.)
ACCESSORIES.
 Speakers, Sin. P.M. with trans., 29/6 and 32/-.
 Speaker transformers, pentode or power, standard fittings, replacement for Rola, Celestion, etc., 6/- each, 65/- doz.
 Replacement bobbins for above speakers, 2/9 each, 27/- doz.
 Screened Mike cable, single 7/6 doz., twin 12/6 doz. yards.
 Screened top cap connectors, all types, 9d. each.
 Volume controls, pilot bulbs, wire, flexes, solder and tape, hundreds of sundries detailed in our catalogue.
TERMS: Prices nett cash.
 Please add postage on small orders. C.O.D. service available. Licensed for export.
THE RADIO INSTRUMENT CO.
 294, BROADWAY, BEXLEYHEATH, KENT.
 Phone: Bexleyheath 3021.

GOOD ADVICE FOR 1944

—order direct from Waveband

Mains Transformer Bobbins, 350-350 v., easily inserted into existing laminations, 4v. or 6v., 18/6. Pen. O.P. Trans., 8/6. 90w. Auto. Trans., 25/-.
New All-in-One. .2a 1,000 ohm voltage Reducer, 5/-.
Barretter replacement for Cl and Clc, 5/-. .3a 750 ohm. Resistor, on Porcl. Former with 2 var. sliders, 7/6. As above, in radiator type cage, with fixing, 10/-. **Razor resistor**, 1,250 ohm with var. taps in safety cage, 7/6.
Compare these values for components:
 ½w. resistors asst. parcels, ½ gross, 24/-. Mica Condensers, all values ½ gr. parcels, 18/-. **SILVER** Mica condensers, fine range, ½ gr. parcels, 20/-. **Radio Fuses**, all sizes and values, 4d.
SERVISOL, New 8 oz. tin-cleans all contacts instantly, 5/-.
Yaxley Wavechange switches, 3/6 ea., 36/- doz. **Big stock** volume controls, less sw. 2, 1, ½, ¼, 100,000, 50,000, 3/6 ea.
A TOOL KIT OF SPANNERS AND SCREW DRIVERS FOR TRIMMING, ETC. 14 parts incl. special extension handles, all in carrying case—a special **WAVEBAND Product**, 30/-.
All technical books offered in last issue of W.W. still available. **Valve Manual**—something **NEW**, 3/6. **Radio Circuits**, for the set constructor 2/-. "Radio Inside Out," a standard reference book for Trader and Amateur, 4/6. **Radio Operators Manual**, 1/-. Three books on Popular American set servicing for 37/6 the set. **Engineering Practice**, fully illustrated, 2/- (incl. extra 2½d. postage on book orders).
 Send 1½d. for the latest **WAVEBAND RADIO MAIL ORDER LIST**—the range of components offered after 4 years of War will surprise you.
EXCLUSIVELY MAIL ORDER.
WAVEBAND RADIO LTD.
 30, Queensgate, London, S.W.5.

£5/15 only.—Brand new super quality 12in. Auditorium permanent magnet speaker with triple cone, manufactured by Bakers Selhurst Radio, the pioneer manufacturers of moving coil speakers since 1925, wide frequency range, even response, ideal for quality reproduction, fitted with 1½in speech coil and magnet having exceptionally high flux density in the air gap, suitable for public address equipment when quality reproduction is first consideration; send 2½d. stamp for leaflet giving details of above and constructional details of a new acoustic chamber designed to extend loud speaker frequency range; also constructional details of an infinite baffle cabinet; every music lover interested in realistic reproduction should write for leaflet.
£8/15 only.—Brand new Super Power 687 Cinema permanent magnet speaker with 18in triple cone; will handle 200 watts U.D.O. ideal for quality public address equipment when power handling capacity plus realistic reproduction is required.—Bakers Selhurst Radio, 75, Sussex Rd., South Croydon. [2394]

LOUDSPEAKERS SECONDHAND
WHARFEDALE Portland, heavy magnet, new, £5; Bakers Selhurst, new, £3.—Tiffany, 9, Marlborough St., Bath. [2346]
TWO brand new 20-watt Goodmans 12in speakers, p.m. type, A2, 15ohm coils; £11/5 each; bargain.—169, Downham Way, Bromley, Kent. [2358]
FOR sale, Voigt speaker, complete with corner horn and power pack; also radiogram and changer; would separate if required.—38, Queens Gate Place Mews, S.W.7. Western 2586. [2399]

Wanted
ROTHERMEL-BRUSH R.155 piezzo-electric tweeter speaker.—Stanton, Ditton Grange, St. Mary's Rd., Ditton Hill, Surrey. [2364]
GOODMANS, 1939, infinite baffle, with or C without trans. to match PX25s in P.P.; catalogue price for new condition.—Box 5037. [2386]

DYNAMOS, MOTORS, ETC.
CRYPTO rotary converter, 220 dc to 230 ac, 75w; £10.—Box 3038. [2387]
BAYLISS rotary converter, 200/240dc input, 7 amp ac output, perfect, full smoothing equip.; cash or exch. gramo equip.—Stainsby, Fairmoor, Morpeth. [2339]
ALL types of rotary converters, electric motors, battery chargers, petrol-electric generator sets, etc., in stock, new and second hand; supplied against priority orders only.
WARD, 37, White Post Lane, Hackney Wick, E.9. Tel. Amherst 1393. [1988]

L.T. dynamos for charging. Lucas-Rotax, 6-12v 9 amps dc, 3rd brush, weight 11lb, size 8in x 4½in, unused ex W.D. cost £10. to clear 17/6 each; ht and lt G.E.C. double-current 6v and 600v, 17lb ditto, 27/6; all carr. paid England and Wales.—Electradix, 214, Queenstown Rd., Battersea, S.W.8. [1748]
ROTARY converters.—E.D.C., 200v dc to 230v ac, 2,000 watts, £35; Crompton 250v dc to 110v ac, 1,500 watts, £25; Crypto 110v dc to 200v ac, 440 watts, £16; ditto 200v dc to 110v ac, 500 watts, £16; Janette 230v dc to 110v ac, 300 watts, £12/10; M.L. 100v dc to 600v dc 100ma, £4 several others; also dynamos and motors.—Below.

ALTERNATOR, Crompton 5kw, 110v 60 cycles, £27; motor alternator, 110v dc input, 75v 7 amps, 190 cycles output, by Marions, £9/10.—Harris, Strouds, Bradfield, Berks.
Wanted
ROTARY converter, 100v. d.c. to a.c., 120 watts from converter.—Box 3021. [2325]
TEST EQUIPMENT
FOR sale, Av0 40, perfect condition; £16.—Box 3041. [2401]
FERRANTI voltmeter, 0-3,500 volts, as new; also valves.—Duncan, Morwenstow. [2328]
TAYLOR model 83A meter, 4,000 o.p.v., new; 15gns.—Heymeson, 315, Welbeck Rd., Carshalton, Surrey. [2341]
UNIVERSAL Avometer, in leather carrying case, hardly been used; offers.—Cridland, Upper Swell House, Stow-on-the-Wold. [2345]
D.C. volt-ammeter, 11 ranges, 200ohms-volt, £9; wanted, panel mounting micro-ammeter.—100, Davies Rd., West B., Nottingham. [2330]

MOVING coil meters, several Ferranti 150ma, one each 7v, 300v, 600v, 750v; two Siemens 150ma, all flush mounting; 45/- each.—Box 3027. [2349]
36-RANGE Av0 Universal and Av0 all-wave battery valve oscillator, in felt-lined case, compartments for tools; £50 or nearest.—Box 3032. [2372]
UNIVERSAL Avominator, new condition, in exchange for high res. d.c. Avominator or Av0 a.c. oscillator; gain adjustment.—Bird, 111, Cecil Rd., Norwich. [2383]
TESTOSCOPe used everywhere by radio service engineers, makes 20 important tests; send for interesting leaflet "R.1."—Rumbaken, Manchester, 1. [1074]

RADIO SPARES

MAINS TRANSFORMERS. Primaries, 200/250v. Secondaries, 850-0-850v.
 Type 46. 120 ma., 4v. 6a., 4v. 2½a. 35/
 Type 63. 120 ma., 6.3v. 5a., 5v. 2½a. 35/-
 Type 106. 100 ma., 6.3v. 5a., 5v. 2½a. 34/-
 Type 186. 180 ma., 4v. 4a., 4v. 6a. CT. 39/6
AUTO TRANSFORMERS. 110/200-250v. 200 Henries, 100 ma. 30/-
OUTPUT TRANSFORMERS.
 Class B. & Q.P.F. 9/-
 Heavy Duty Pentode, 100 ma. 13/6
 25/30 ma., Midget 9/6
 Battery, Midget 12 ma. 12/6
CEXOS. Smoothing.
 200 Henries, 100 ma. 12/6
MAINS DROPPING RESISTORS.
 2a. 950 ohms, 6/9; .3 a. 800 ohms 6/9
 Fitted with sliding clip and provided with feet for chassis mounting.
LINE CORD.
 3 way 3a. (approx. 185 ohms) per yard 7/-
 2 way 2a. (approx. 185 ohms) per yard 5/3
FIELD COILS, HEAVY DUTY, 1,500 ohms.
 2,000 ohms and 200 watts 12/-
SPEAKERS. Celestion P.M. 8", with Transformer 27/6
 Delay in delivery may arise owing to demand, but every effort will be made to despatch as soon as possible.
PLEASE NOTE.—Orders accepted by post only, and those of 10/- or less should be accompanied by cash. Please include postage with order. Orders over 10/- in value can be sent C.O.D. PRICE LIST 2½d. stamp.
Licences for Export to N. Ireland & Eire.

H. W. FIELD & SON
 14, Colchester Road, Harold Park, Essex.

ENGINEERING

OPPORTUNITIES

This unique handbook shows the easy way to secure A.M.I.Mech.E., A.M.Brit.I.R.E., A.M.I.E.E., CITY and GUILDS, etc.
WE GUARANTEE 'NO PASS—NO FEE'
 Details are given of over 150 Diploma Courses in all Branches of Civil, Mech., Elec., Motor, Aero, Radio, Television and Production Engineering, Training, Building, Govt. Employment, R.A.F. Maths, Matric., etc. Think of the future and send for your copy at once FREE.
B.I.E.T., 387, SHAKESPEARE HOUSE, 17, STRATFORD PLACE, LONDON, W.1

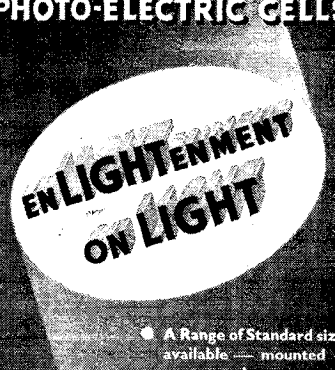
SALFORD Selenium
PHOTO-ELECTRIC CELLS

 A Range of Standard sizes available—mounted or unmounted.
 Special sizes to order.
 Please address enquiries to—
SALFORD ELECTRICAL INSTRUMENTS LTD.
 PEEL WORKS, SALFORD, 3.
 Telephone: BLAithwaite 6488 (6 lines) —Telegrams: Salfeld—Salford
 PROPRIETORS: THE GENERAL ELECTRIC CO. LTD. OF ENGLAND

PREMIER RADIO

PREMIER MICROPHONES

Transverse Current Mike. High-grade large output unit. Response 467-7,500 cycles. Low hiss level. 23/-.
 Premier Super-Moving Coil Mike. Permanent Magnet model requiring no energising. Sensitivity 56db. Impedance 15 ohms. Excellent reproduction of speech and music. £5/5/-.
 Microphone Transformers, 10/8 each.
 Crystal Mike. Response is flat from 50-5,000 cycles with a slightly rising characteristic to 8,000 cycles. Output level is minus 60db. Price 39/6.
 Chromium Collapsible Type Microphone Stand, 52/6.

ROTAX METERS

30 amps. centre zero, bakelite case . . . 19/6 each

CHASSIS

Lead coated steel, un drilled.
 10" x 8" x 2 1/2" price 7/- each.
 16" x 8" x 2 1/2" price 8/6 each.
 20" x 8" x 2 1/2" price 10/6 each.

LF. TRANSFORMERS. IRON CORED

450-470 kcs., plain and with flying lead, 7/6 each.
NEW PREMIER S.W. COILS
 4- and 6-pin types, now have octal pin spacing and will fit International Octal valve holders.

4-PIN TYPE			6-PIN TYPE		
Type	Range	Price	Type	Range	Price
04	9-15 m.	2/6	06	9-15 m.	2/6
04A	19-26 m.	2/6	06A	19-26 m.	2/6
04B	22-47 m.	2/6	06B	22-47 m.	2/6
04C	41-94 m.	2/6	06C	41-94 m.	2/6
04D	76-170m.	2/6	06D	76-170 m.	2/6
04E	150-350 m.	3/-	CHASSIS MOUNTING		
04F	255-550 m.	3/-	OCTAL HOLDERS		
04B	490-1,000 m.	4/-	10id. each.		
04H	1,000-2,000 m.	4/-	10id. each.		
New Premier 3-Band S.W. Coil. W.I. 11-25, 25-38, 38-86 m., 4/8.					
Rotary Wave Change Switch, to suit above, 1/6.					
Bakelite Dielectric Reaction Condensers.					
0001 mf. 1/3 0003 mf. 2/6 0005 mf. 2/9 each					
305 mf. Differential 2/11 each					

H.F. CHOKES

S.W. H.F. Choke, 10-100 m. 1/3
 Binoocular H.F. Choke 1/6
 Brass Shaft Couplers, 1/4 in. bore 7/4d. each
 Flexible Couplers, 1/4 in. bore 1/6 each
 7-pin Ceramic Chassis mtg. English fitting Valve Holders, 1/6 each.
 Amphibol Octal Chassis mounting Valve Holders. International type, 1/3 each; English type Octal, 1/3 each.

RESISTANCES

Mains Resistances, 660 ohms .3A Tapped. 360 x 180 x 60 x 60 ohms, 5/6 each.
 1,000 ohms, .2A Tapped. 900, 800, 700, 600, 500 ohms, 5/6 each.

SWITCHES

QMB, panel mounting, split knob type, 2 point on/off, 2/- each. Double pole on/off, 3/6 each.

VOLUME CONTROLS

Carbon type, 20,000, 1 meg. and 2 meg., 3/9 each.
 5,000, 10,000, 4/6 each.
 Wire Wound Type, 5,000 and 10,000 ohms, 5/6 each.
 Valve Screws for International and U.S.A. types, 1/2 each.
 Resin-Cored Solder, 7/4d. per coil.
 Push-Back Connecting Wire, 2 1/4d. per yard.
 Systoflex Sleeving, 2 mm., 2/6 per doz. yards.
 Sorenson Braided Cable, Single, 1/3 per yard. Twin, 1/6 per yard.

MOVING COIL SPEAKERS

Goodmans 3 1/2 in. P.M. Speaker, 15 ohms voice coil, 30/-.
 Rola 3 1/2 in. P.M. Speaker, 3 ohms voice coil, 25/-.
 Rola 5 in. P.M. Speaker, 3 ohms voice coil, 25/-.
 Above speakers are less output transformer.
 Pentode Output Transformers, 3 1/2 watts, price 10/6 each.
 Celestion 5 in. P.M. Speaker, 29/6.
 Celestion 10 in. P.M. Speaker, 49/6.
 The above speakers are fitted with output transformers.
 Morse.—The Premier Oscillator supplied complete with valve, on steel chassis, price 27/6. Practice key 3/3, TX key 5/10, Super key 11/6. 3-Henry Chokes (as used in Oscillator), 10/- High pitched Buzzer, adjustable note, 1/11 each.

Send for details of other Accessories available.

ALL ENQUIRIES MUST BE ACCOMPANIED BY A 2 1/4d. STAMP.

PREMIER RADIO CO.

ALL POST ORDERS TO:

JUBILEE WORKS, 167, LOWER CLAPTON ROAD, LONDON, E.5. (Amherst 4723).

CALLERS TO:

JUBILEE WORKS or 169, FLEET STREET, E.C.4. (Central 2833.)

AVO model 40, 954, 955 acorns; offers: m/c v/m (5ma. F.S.D.), 45/-, all brand new. Weston Photronic cell, offers. Pye 100megohm Wheatstone, £6. Wanted, General Radio oscillator, bridge, etc.; state age, price.—Box 3035. [2382]

FOR sale, 1 high voltage air condenser tester, Scott; 1 Audio oscillator, type 813a. General Radio; 1 diode coil tester, Scott; 1 valve volt meter; 1 d.c. volt meter, 0-10, Weston; 1 high resistance ohm meter, Weston.—Tel. The Dulci Works, Willesden 7778-9. Mr. Barr. [2324]

Wanted

WANTED, Hallicrafters signal strength meter, type SM18.—Offers to Box 3036. [2385]

MAINS signal generator, H.R. Avomitor, 72 Taylor 90.—4, Hollingbury Gardens, Worthing. [2390]

GENERAL radio 650 A. or Marconi instruments T.F. 373, or similar impedance bridge; G.R. 583 A. or M.L., or similar multi-impedance output power meter; G.R. 728 A. or similar valve voltmeter.—Price and full particulars to Box 3040. [2396]

NEW MAINS EQUIPMENT

VORTEXION mains transformers, chokes, etc., are supplied to G.P.O., B.B.C., L.P.T.B.; why not you? Imitated but unequalled; orders can only be accepted against Government contracts.

VORTEXION, Ltd. 257, The Broadway, Wimbledon, London, S.W.19. Lib. 2814.

FOR sale, the following converters, with starters, as new: By Watson, London, d.c. input 220v, a.c. output 140, 650 v.a., £27/10; by Medical Supplies, London, d.c. input 240v/163 a.c., output 140v, 1.5 kva, £25; by Watson, London, d.c. input, 240v a.c., output 140v, 1 kva, app., £22/10; another, as new, d.c., input 220v a.c., output 230v, 1 kva, £35; all carriage forward.—Dudley, 123, Norton St., Nottingham. Tel. 76935. [2353]

MAINS EQUIPMENT—SECOND-HAND

DAVENSETT Type G.C. charger, three bank; £25, offers.—Box 3039. [2391]

CRYPTO batt. charger, type R4, new Philips rect., good cond.; £25, offers.—Box 3025.

POWER transformers, by Foster, 1.7 kW, 200v to 15v 113 amps, £7/10; 200v to 240v 9 amps, tested 2,000v, £7/10; 200v to 100v 50 amps, £12/10; 220v to 230v 10kVA, £9; 100v to 8,800v 3 kVA, £3; 190-215v to 3-0-3v, 50 watts, £1/10; 200v to 18v 22 amps, £4; 220v to 1,000-0-1,000v 2kVA, £5/10; 200v to 15v 10 amps, tested 10,000v, £3/10; 200v to 20v 40 amps, tested 20,000v, £5; 220v to 4,000-0-4,000v, 1,000 watts, tested 8,000v, £6/10; 200v to 1,500v 150 watts, tested 6,000v, £3/10; 150v to 26v 43 amps, £7; Gresham 230v to 40v, 40 watts, £2; Parmico 200-250v to 250-0-250, 100 mA, 2-0-2v 3 amps and 2-0-2v 1 amp, wt. 15lb, £2/10; 200-250v to 2v 10 amps, £1/10; all above single phase 50 cycles.—Harris, Strouds, Bradford, Berks. [236/]

MORSE EQUIPMENT

MORSE practice equipment for class-room or individual tuition; keys, audio oscillators for both battery or main operation.—Webb's Radio, 14, Soho St., London, W.1. Tel. Gerrard 2089. [2291]

GRAMPHONE AND SOUND EQUIPMENT
MARCONI autochange mechanism, 8-10in or 12in, reject lever; 21gns.—Box 3030. [2366]

COILS for filters, tone controls, etc., all types transformers for "W.W." circuits.—R. Clark, 30, Langland Cres., South Stanmore, Middx. [2275]

RECORDING cutters.—We can supply first-class steel cutters at 8d. each; cash with order only.—The Bishop Sound and Electrical Co., Ltd., 108, Beverley Way, London, S.W.20.

AC/DC Grampan 4-5 watt portable amplifier, m.c. mike, adjustable stand, m.c. l.s., tone control, mike and gram. vol. controls, excellent condition: £18.—40, Morley St., Bury, Lancashire. [2365]

£3, Baker 12in energised speaker; also £3, 12in P.M.; 4-watt a.c. amplifier, £5; crystal pick and turntable, shabby, £5; Cosmo-cord crystal Plusagram, £10; Avomitor universal, £9; Baker 2R.F. feeder and 7-valve Q.A., new, £25.—Box 3029. [2356]

Wanted

RIBBON microphone required (preferably Amperite); state price and condition.—Phillips, 51, Evelyn House, Oxford St., W.1. [2355]

COMPONENTS—SECOND-HAND, SURPLUS
LONDON CENTRAL RADIO STORES.—See our displayed advert., page 9 this issue.—London Central Radio Stores, 23, Lisle St., London, W.C.2. Ger. 2969. [2359]

ELECTRADIX

Selection of Bargains

SPECIAL BARGAIN. 1/5th H.P. and 1/4th H.P. D.C. Motors, enclosed, silent, 230 to 250 volts 1500 revs. Double end shaft, first grade make, guaranteed. 1/5th H.P., £3 10s.; 1/4th H.P., £4.

MOTORS AND DYNAMOS. D.C. Motors in all sizes from 1/8th H.P., 1/6th, 1/4th, 1/3rd, 1/2, 3, 1, 1 1/2, 2, 3, 4, 5 and 6 H.P., in 110, 220 and 440 volts. A.C. Motors, single and 3-phase, from 1/8th H.P. to 3 H.P. Kindly specify wants and we will offer the nearest.

BLOWERS AND FANS. Exhaust and open type of 1/6th to 6 H.P. available.

PORTABLE ELECTRIC DRILLS. D.C., 110 volts, £5 10s.; A.C., 220 volts, £7 10s.

DRILLS. Electric Bench Drills, D.C. Wolf, 110 volts, massive pillar type, £8 10s.

PUMPS. Stuart motor pumps, centrifugal, C.D. Shelter, 12 volts D.C. or 230 volts A.C. in stock. Twin-piston pumps with or without motors, for suds or water.

TRANSFORMER COMPONENTS. Stampings Control limits supply. We offer some 100-watt transformers for rewinding. Complete, good class but unknown ratios. Sold for re-making, 22/6. Larger, 250-watt size, 27/6. Stalloy Sheets for Transformer Stampings, 38in. x 6in., 1/3 each.

POWER TRANSFORMERS. Single phase 50 cycles 35 KVA, 35,000 watts, by Brit. Elec. Transf. Co. 220 volts to 110/110 volts, £30. 5 KVA 220 volts to 5,000 volts and 500 volts, £10. 2 KVA Foster 200 volts to 4,000 volts, £8 10s. 1 1/2 KVA Zenith 100 volts to 6,000 volts, £8. 3KVA 400 volts S.P. 50 cycles to 600 volts, oil filled, by Metvick, £9. All as new.

COVERS. Light Metal ventilated covers for test boards, resistances, chargers, etc., special arch shape to contain 6 1/2 in. x 5 in., with terminal cover extension, 3/-, postage 6d.

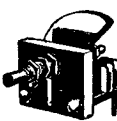

CONDENSERS. Ultra Short Wave variable air condensers. Trolitul insulation ball-bearings. Surplus to a Govt. contract and new, 5/-, G.P.O. Lab. Switches, D.P., reversing for model control motors and test work, 7/6.

CRYSTAL SETS. Gambrell W/M type with crystal switch, tuning condensers and permanent crystal detector, in closed portable case, 50/-.
Victory Pocket type crystal receiver in bakelite box, with one earpiece, 35/-.

AERIAL WIRE, 7/22 bare copper, 5/- per 100ft. Lead-in wire, 4d. per yard. Aerial insulators, 2d. each.

HEADBANDS only for 2 earpieces, 2/6. **Govt. Cords, 2/6. MORSE KEYS.** We have some ex-G.P.O. Quad Keys, in blitzed condition, needing overhaul, 12/6. Keys from 5/- each.

SUNDRIES. H.M.V. Resistors, glass cased wire ends, 1/2 watt, .01, .025, .05, 1/- per set of 3, or 2/6 per doz. **Screened Mike Cable,** flexible sheath, single core, 1/2 per yard.

6 MERCURY VAPOUR LAMPS, 400-watt Philips "Philora," with chokes, condensers, lampholders and 20in. Reflectors, for sale singly or as one set.

Mentor Battery Indicators, thermal type signa light, thermal type, 2 1/2 in. dial, flush panel, 6 volt and 12 volt, 5/-. **Small Soldering,** "Gemi," 6 volts, 1 1/2 amps., iron plunger, 6/6. **Oldhams Miners Lamps,** all-metal, for accumulator or dry cell, 7/6. **4-way Cords,** long, suit mikes or handcom phones, 2/-. **Electric Counters** to 10,000 revs., G.P.O., 5/6.

Multiple Connection Strips, of soldering tags, telephone type moulded mounting, in 20, 40, 80 or 100 ways, at 2/6, 3/-, 3/6 and 4/- each. **G.P.O. Plugs,** 2/- each. **Terminal Covers,** bakelite, with two securing screws size of domino, 9d.

Please send stamped envelope for answer to enquiries and include postage for mail orders.

ELECTRADIX RADIOS

214, Queenstown Road, Battersea, London, S.W.8
 Telephone MACaulay 2169.

Of course we're Proud

Justifiable pride has never yet carried harm in its wake. Rather does it act as a spur, to even greater efforts, for the slightest slackening of purpose may turn it into mere arrogance and vainglory. Which is why that at Gardners Radio you will find us very jealous of the pride we take in building components as good as they possibly can be. And nowhere in the Gardner range is this pride more justified than in the Small Power Transformers up to 4 kva. So when next you need this type of product why not let us prove to you how justified we are in being proud.

We regret that at present Small Power Transformers are available for highest priority orders only.



GARDNERS RADIO LIMITED
SOMERFORD · CHRISTCHURCH · HANTS

YOU can become a first-class RADIO ENGINEER

We are specialists in Home-Study Tuition in Radio, Television and Mathematics. Post coupon now for free booklet and learn how you can qualify for well-paid employment or profitable spare-time work.

T. & C. RADIO COLLEGE
2 The Mall, Ealing, W.5

(Post in unsealed envelope, 1d. stamp.)

Please send me free details of your Home-Study Mathematics and Radio Courses.

NAME

ADDRESS

G. A. RYALL, 69, Wharfedale Gardens, Thornton Heath, Surrey.—Please note new temporary address; mail order only; no c.o.d. under 20/- please.

ERIE resistances.— $\frac{1}{2}$ W. 680 ohms, 3/- doz.

T.C.C. 0.1 non-induct. tubul. condensers, in wax tubes, type 330, 350v wks., 7/6 doz.

SLOW motion (epicyclic) drives, in well-finished brass, ratio 8-1, shaft $\frac{1}{8}$ in long, $\frac{1}{4}$ in dia, drilled to take pointer, 1/3 each.

PAXOLIN strip, $\frac{2}{32}$ in wide, 12in lengths, 3 1/6 and 100 25/-; short lengths cut group board size, 6 1/5.

TEHMBLE top caps, 24 1/3; insulating tape, black, 1/3 lb; Wearite switches, ebonite with silver-plated contacts, for 2Wf and band pass with dial lights, 1/6 each.

YAXLEY switch screens, size approx. 4in \times 3in, drilled mtg. flange, 3 for 1/3.

5-PIN plugs and sockets, complete with metal insulated cap 2 for 1/6.

DIAL plates, oblong, $5\frac{1}{2} \times 2\frac{1}{2}$ approx., Burndept, Varley, Vidor, with station names, 4 assorted for 1/6.

BURNDEPT portable set dials, $4\frac{1}{2} \times 2\frac{1}{2}$ approx., two types, 2, 1/3; Burndept 4-band, $8 \times 5\frac{1}{2}$, s.w. on lower half dial, 1/6 each; Vidor 3-band, $6\frac{1}{2} \times 5\frac{1}{2}$, 1/6 each.

COILS iron core midget, Litz wound, medium wave tapped, no reaction, 2/3 each; push-back wire stranded, cotton covered, 3 colours, 12 yards, 2/3.

T.C.C. double 0.0001 \times 0.0001 mica condensers, 3, 1/3; Hunts 0.01 mica, 1/- each; twin rubber flexible, one cover, for essential replacements, 5 yards, 6/6.

MICROPHONE capsules by Standard Telephones, 3/9 each; Centralab volume controls, bass switch, long spindles, 5,000 ohms, $\frac{1}{4}$ meg, $\frac{1}{4}$ meg, 3/9 each; unused 10-way flexible stranded wire, 2/- yard.

CENTRALAB volume controls, short spindle, $\frac{1}{2}$ meg. less switch, unused, 2/10 each; twin screened, flexible, 1/3 yard; ditto, high insulation and cotton out cover, 1/9 yard; ditto, 4-way, 2/3 yard.

ERIE colour coded resistances. 2-watt type, 680, 6,800, 140,000, 150,000, 220,000, 470,000, 820,000, 2, 1/6; Erie 3-watt, 680, 6,800, 1/3 each; wound ebon. bobbins, 5,000 ohms, slotted to take Hiflux iron 100v, 1/3 ea. [2357]

LASKY'S RADIO, 370, Harrow Rd., Paddington, W.9, offer for sale the following components: special bargains for set builders: grey cellulosed steel radio chassis, complete with l.f. and aerial coils, trimmers, condensers, a. and cath. sockets, 8 valve holders, resistors, and many various components, etc.; size 8in \times 12in \times 1 $\frac{1}{4}$ in; special offer, 26/-, post free. 0.02mfd 2,000v at 1/- each; 0.25mfd 2,000v 1/6 each; 0.05mfd 500v at 1/- each; 2mfd 600v block at 2/6 each; 50mfd 12v. at 1/4; 10mfd 25v at 1/6 each; 0.1mfd 350v at 6d. each; speakers, Rola p.m., 5in, at 19/6; 6 $\frac{1}{2}$ in at 21/-; 8in at 23/6; all less transformer; Goodman's, 3 $\frac{1}{2}$ in at 27/6. 5in at 21/6; special offer, 10in at £2/5, post extra; send us your requirements. [2347]

RECTIFIERS.—Metal rectifier, 2v half amp, complete with transformer, makes an ideal trickle charger for 2v accumulator. 13/6, post 7d.; transformer, metal rectifier, ballast bulb, for 2v, 6v, 2 amp charger, 42/6, postage 10d., no ammeter or rheostat needed; instrument type rectifiers for meters, bridge type, bakelite, brand new goods, 1ma 18/6, 5ma, 10ma, 50ma, 15/6, postage 3d.; microphones, Rothermel Bullet crystal microphones, head-lamp shape, black crackle finish, knuckle joint, still the best value in crystal microphones, and gives quality equal to a far more costly type, £3, postage 10d.; D.10A crystal microphones, plated housing, aluminium diaphragm, £4/15; moving coil microphones, less transformer, £4/15; Rothermel bakelite senior crystal pickups, £3/18/6.—Champion, 42, Howitt Rd., London, N.W.3. [2374]

COULPHONE Radio, New Longton, nr. Preston.—New goods only: Tungram valves, British and Amer. rectifiers, 10/6; mains transf., 350v 100mA, 4v 6A, 4v 2 $\frac{1}{2}$ A, 32/6; 350v 120mA, 6.3v 3A, 5v 3A, 33/6; mains transf. bobbins, std rep Eng. and Amer., 18/6; Rola p.m., less transf., 5in 21/6, 6 $\frac{1}{2}$ in 22/6, 8in 24/-; Celestion 8in p.m. with trans. 30/-; 10in Heavy Duty with trans. 45/-; cored solder, 4/6 lb.; tin. cop. wire, 2/3 $\frac{1}{2}$ lb; 2mm Systoflex, 5d. yd.; line cord replace, resist. 800 ohm, 2 adj. taps, 6/9; Parafed l.f. transf. 4:1, 5/-; 50mfd 12v 2/-, 25mfd 25v 2/-; Erie resist., 1w 9d., $\frac{1}{2}$ w 6d., $\frac{1}{4}$ w 4d.; pushback wire, 100ft 6/-; switch cleaner, 2/3 bott.; power-pentode out. trans., 7/6; bell transf. 6/6; valveholders, 1d. per pin; Stanelco l.f. solder, irons, 21/-; tub. and mica cond., V cont., with sw. 5/9, less sw. 4/9; 450w. iron elements, 2/3; s.a.c. or stock list. [2336]

Yours to a tenth of a thou'

A highly skilled staff of craftsmen combined with the most up-to-date machines enable us to handle light engineering production with microscopic accuracy. We also realise that you want delivery promises kept.

Wingard
(M.A.) LTD.

Precision Engineers
EUGENE WORKS, EDGWARE ROAD, HENDON, N.W.9

R. K. Stundas

LIMITED

Experimental and Aeronautical Engineers and Scientific Instrument Makers. Manufacturers of Precision Mechanical, Electro-Mechanical and Thermionic Instruments. Electro-Medical and Industrial Apparatus, Time Interval Measurement and Counters, DC Amplifiers and Recorders. Specialised Design Enquiries Welcomed

THE AIRPORT, PORTSMOUTH
Telephone : 74874.

RELAYS
TYPE LF

WORK IN ANY POSITION

Specified by many Government Departments.

Ask for leaflet SPN/WW.

LONDEX LTD
MANUFACTURERS OF RELAYS
ANERLEY WORKS, 207 ANERLEY ROAD, LONDON S.E.20

LOW VOLTAGE BULBS
FOR ALL PURPOSES

SPOT BULBS, DYNAMO BULBS, RADIO PANEL (Indicator) BULBS, ELECTRIC LAMPS, TORCH CASES, BATTERIES.

SUPLEX LAMPS LTD.
Appointed B. O. T. IMPORTER SELLING AGENTS
50, GRAY'S INN ROAD, LONDON, W.C.1.
Tel. : HOLBORN 0225

PRACTICAL BOOKS

PROBLEMS IN RADIO ENGINEERING

By E. T. A. Rapson, A.C.G.I., D.I.C. A classified collection of examination questions in Radio Communication, together with some useful notes and formulae and answers to those questions. Fifth edition. 5s. net

CLASSIFIED RADIO RECEIVER DIAGRAMS

By E. M. Squire. A diagrammatic survey of modern radio receivers. Provides the practical radio man, service engineer, dealer and amateur with a ready reference to a representative selection of the types of circuit likely to be met with in the majority of receivers. 10s. 6d. net

BASIC CALCULATIONS FOR RADIO, WIRELESS AND ELECTRICAL TRADES (R.A.F.)

By A. E. Druett, B.Sc. (Eng.) Lond., A.M.I.Mech.E. Applies to R.D.F. and Wireless Mechanics, Wireless Operators, and Electricians, Groups I and II. The proficiency examination is adequately covered, and fully worked solutions are included. 3s. 6d. net

ACCUMULATOR CHARGING, MAINTENANCE AND REPAIR

By W. S. Ibbetson, B.Sc., A.M.I.E.E. Filled with highly-compressed, but clear, information and in it the ordinary user will find everything he needs to know about the charging and upkeep of accumulators for all purposes. 6s. net. Eighth Edition

The books advertised may be temporarily out of stock when you place an order. If you have any difficulty in securing copies of Pitman Books through your bookseller, write to Enquiry Department, Pitman House, Kingsway, London, W.C.2. Please do not send money when making enquiries.

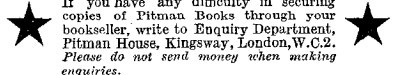

Write for Pitman's Radio List. Published by **PITMAN** 39, PARKER ST., KINGSWAY, W.C.2

MARCONIPHONE, h.t. and l.t. supply unit from a.c. mains, supplies 250v, 60 ma. 4v-4a, 6v-1a; £3.-A. H. W., 59, Hillington Gardens, Woodford Ave., Woodford, Essex.

ROLA G12, B.T.H. R.K. loud speakers, electric gramophone motor, numerous components; send stamped addressed envelope for list.—Castagnoli, 71, Culver St., Colchester. [2354

SOUTHERN RADIO'S wireless bargains: Screws and nuts, assorted gross of each (2 gross in all), 10/-; soldering tags, including spade ends, 6/- gross; Philco 3-point car aerials, excellent for short-wave and home aerials, 7/6; Limit tone arms, universal fixing for all types of sound boxes and pick-up heads, 10/-; Ace "P.O." microphones, complete with transformer, ready for use with any receiver, 7/-; circular magnets, very powerful, 1 1/2in diameter, by 3/4in thick, 1/6 each, 15/- per doz.; Erie resistances, brand new, wire ends, all low value from 0.8 ohms upwards, a few higher value are included in each parcel, 1/4, 1/2, 1 and 2 watt, 100 resistances for 30/-; Multicon Master mica condensers, 28 capacities in one from 0.0001, etc., etc., 4/- each; special assorted parcel for service men, 100 Erie resistances (description above), 24 assorted tubular condensers, 6 reaction condensers, 0.0001, 12 lengths insulated sleeving, 75ft. push-back connecting wire, soldering tags, screws wire, etc., 65/- all brand new; crystals (Dr. Cecil), 6d., with cats-whisker 9d.; complete crystal detectors, 2/6; 75ft. wire for aerials, etc., 2/6; 25yds push-back wire, 5/-; Telsen reaction condensers, 0.0001, 1/9 each; Telsen large disc drives, complete with knob, etc. (boxed), type W 184, 2/6 each; insulated sleeving, assorted yard lengths, 3/6 doz.; single screened wire, doz. yards, 10/-; loud speaker units, unshrouded, midge type, 4/-; metal case condensers, 0.1 +0.1-0.1, 2/6; rheostats, power type, 30 ohm, 4/6; pointer knobs, black and brown, 1/4in, 1/-.—Southern Radio Supply Co., 46, Lisle St., London, W.C. Gerrard 5653. [2152

Wanted
WANTED at once, 3 Varley BP80 coils, must be O.K.—Hanson, Lomond House, Rochdale. [2343

WEARIE Universal coil, type A, for S.T.I.S.—Cooper, 33, Caledonia Cres., Gourcock, Scotland. [2375

WANTED, P.P.P. 8:1 or 9:1 intervalve trans.—Parties, to A. Lyon, "Kempshot," Brougham Rd., Worthing. [2369

HEAVY plated ring for suspending microphone in (round preferred), 5/16 or 1/4in. thread, for stand mounting.—Watkins, 4, Park End, Paganhill, Glos. [2379

CABINETS
HIGH class radio cabinet, veneered walnut, inside measurement 15x15x9, £4/10; Console cabinets, with undrilled panel, 37x19 x16 wide, £7/10; photos 1/6 each (returnable)—H. L. Smith and Co., Ltd., 289, Edgware Rd., London, W.2. [2392

NEW and modern design loud-speaker cabinets, fitted with loose baffle boards, size 13inx12inx7in, polished oak or walnut, in stock for immediate delivery, 17/6 each; any type or design of cabinet made to order, wholesale only.—Send your enquiries to Waldenberg Bros., Ltd. (est. 1896), New York Rd., Leeds, 2. Tel. 22490. [2249

VALVES
5000 valves, all types, including output, rectifiers, etc., s.a.e.—Davies, 28, Mount Vernon Crescent, Barnsley. [1848

OUR adaptors will help in replacing unobtainable valves; send 7d. for interesting booklet on valve replacements; trade enquiries invited.—V.E.S., Radio House, Ruislip. [1885

VALVES.—We have over 5,000 new and boxed English and U.S.A. mains and battery valves in stock, including 6A7, 6A8, 25Z4, 75, 5Z4, U50, 50Z5, 50L6, 35L6, 6F6, 6C13c, VP2, SP4, PX4, PENA4, ACPENDDD, TDD4, UU5, 6K7, 117Z6, 6Q7, 6K8, 6X5, 6B8, IW4, 350, U12, 12A8, 12Q7, 6SA7, 6SK7, PEN36c, etc., etc.; send us your requirements.—Lasky's Radio, 370, Harrow Rd., Paddington, W.9 (opposite Paddington Hospital). [2343

1000 valves in stock.—CYIC, 11/-; UR3C, 11/-; U10 11/-; VP23, 11/-; AC2/ PenDD, 15/3; AC5/PenDD, 15/3; Pen DD-4020, 15/3; VP13C, 12/10; SP15, 12/10; Pen A4, 12/10; 80, 11/-; 78, 12/10; 45, 11/7; 42, 12/10; UU5, 11/-; U31, 11/-; 1W4/250, 6/6; HL23, 5/10; AC/THI, 14/-; SP41, 12/10; EM3, 10/5; AZL 11/-; 36, 12/10; C66, 12/10; IC5GT, 11/-; IH5GT, 9/2; 35Z4GT, 11/-; send s.a.e. for valve and wireless parts lists, 2d.—Ransom, 9 and 34, Bond St., Brighton. Retailers not supplied. [2397

AUSTERITY RADIO LIMITED

Formerly F. H. Wilson
CONSTRUCTORS' KITS
3-v. T.R.F.

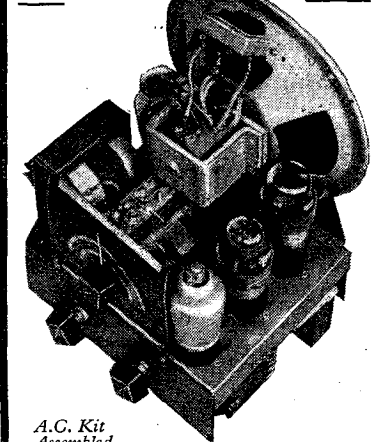

A.C. Kit Assembled.
Delivery approximately One Month.

When assembled these Kits give excellent reproduction on Medium and Long Waves. Supplied complete with chassis 6in. x 6 1/2in. x 2 1/2in., Valves, M.C. Speaker and wiring diagram. (Regret, no cabinets.) 3 controls. A.C. 3-V. (+ RECTIFIER) KIT. V.M.H.F. Pen, Triode, L.F. Pen, Rectifier, M.C. Speaker. Price 10/6. Post 1/1, plus 3/6 packing (returnable).
BATTERY 3-V. KIT V.M.H.F. Pen, Triode Detector and Output Tetraode, P.M. Speaker. Price £7. Post 1/1, plus 3/6 packing (returnable).
3-GANG CONDENSERS, ceramic insulation, .00025, 7/6; .0005, with trimmers, 10/6.
AERIAL AND H.F. TRANSFORMERS with reaction medium and long waves. Iron-cored on medium waves loading coil on long waves. 10/- per pair.
A. & H.F. TRANSFORMERS with reaction colour coded. 10/6 a pair.
SCREENED DUAL RANGE COILS, Long and Medium. Aerial and H.F. Transformers with reaction. Size 2 1/2 dia. x 2 1/2in. Iron-cored on medium wave only. With circuit blue print. 12/6 a pair.
465 KCS. I.F. TRANSFORMERS. Air-cored, screened, with trimmers. 15/- a pair. 465 KCS Permeability tuned. Iron-cored, screened. 15/- a pair.
UNIVERSAL MAINS TRANSFORMERS, A.C. input, 230 v. output, 300-0-300, 6.3 v., 4 amp., 5 v., 2 amp., 4 v., 2 amp., 4 v., 4 amp., 80 m.a. Screened primary colour coded—a good replacement transformer, especially for sets using mixed valves, 32/6 each.
STANDARD REPLACEMENT MAINS TRANSFORMERS, input 200/250 A.C., output 350-0-350, 150 m.a., 6.3 v., 5 amp., 5 v., 2 amp., 35/- each.
1000S VOLT DROPPING RESISTORS, 2 amp. 10,000 ohms, 2 variable sliders, 6/-; 3 amp. 750 ohms, 2 variable sliders, 7/-.
10-WATT WIRE-WOUND RESISTORS, 2,000, 1,000, 500 and 150 ohms, 2/6 each.
PADDERS. Twin ceramic .0005 mfd. and .001 mfd. (max.), 2/6 each.
VOLUME CONTROLS, 1 meg., with switch, 6/6 each. 25,000 and 50,000 ohms, less switch, 4/- each.
COMBINED VOLUME CONTROL, 100,000 ohms and Reaction Condenser, 6/6.
CHASSIS. Undrilled steel, painted, new, 10 1/2 x 8 x 2 1/2in., 7/6; 8 x 6 x 2 1/2in., 4/6 each.
TERMINAL STRIPS, 8" x 1" Aerial, I.R.H. Mains, etc. Earth P.C. & 3 Mains Sockets, 1/8.

★ Please add postage for enquiries and orders, G.O.D. orders accepted.
Licence to export to Northern Ireland and Eire. Owing to present circumstances, prices are subject to increase without notice.

307, HIGH HOLBORN, LONDON W.C.1. Phone: HOLborn 4631

Answers!
FLIK-O-DISK
Quick!

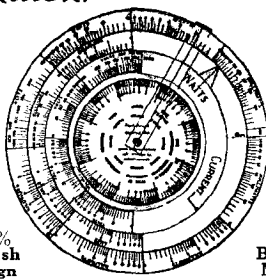

100% Bitish Design
100% British Made

Answers all OHM'S LAW problems—for example:
What will be the voltage when current I flows through resistance R?
What will be the voltage with watts value W and I current flowing?
What is the current flowing where watts value is W and voltage is E?
What current will flow through R resistance where voltage is E?
What will be the resistance where current I flows at voltage E?
What will be the resistance where watts W is at voltage E?
What will be the resistance where watts W at current I?
What is the wattage at voltage E through resistance R?
What is the wattage of current I through resistance R?
What will be the wattage of I current at E voltage?
The scales read from 1 millivolt to 1,000 volts. From 1 ohm to 1,000,000 ohms. From 1 milliamper to 10 amperes. From one-tenth of a milliwatt to 10,000 watts.

FULL INSTRUCTIONS WITH EACH INSTRUMENT.
PRICE 4/6 Postage 3d.
Order at once whilst deliveries are good
IONIC LABORATORIES LTD.
6 Cranbourne Terrace, Salt Hill, SLOUGH, BUCKS, ENG.

Come to the point!

It's hot—all the time! That's because the heating element is housed inside the bit in the Solon Electric Soldering Iron. Soldering is easier; you get a neater cleaner job in less time. All internal connections are housed at end of handle away from heat. A robust cord grip prevents sharp bending of the flexible lead. Complete with 6ft. Henley 3-core flexible Solon irons are made for the following standard voltages:—100/110, 200/220, 230/250.

Supplies are, of course, only available for essential war work. Early orders are advisable, as demands are heavy.

Made in England

Illustration shows a 125-watt standard model.



W. T. HENLEY'S TELEGRAPH WORKS CO. LTD.
Engineering Dept., Milton Court, Westcott, Dorking, Surrey

10/- each, HF pens, freq. changers, etc., VMS4, VP4, AC/SG, 6A7, 6A8, 6K7, DH42, SP13, AC/TP, AC/TH1, X41, X42, 41MPG, etc.; list price, no purchase tax triodes, output pens, etc.; c.o.d. or cash with order.—65, Carlton Mansions, Randolph Ave., London, W.9. [2400]

UNUSUAL valves, second-hand, offered at pre-war list price, eminently guaranteed; a few each of following types available: Philips DC1/50, 367, 1102, 329, 1562, 340; Bdiswan ESU/40, 68530, HTB1; Mullard DO60, RG2/500, DO25, DW3; Osram GU1, U8, LS5, LS5A, LS6A, LS2, V24, QX, U2, U6; Mazda PX650, U75/300; Raytheon BA, BH; Cossor 6608U; postage and packing extra and at purchaser's risk.—Harris, Strouds, Bradford, Berks. [2361]

VALVES. British and American, many types in stock; Midget aerial and hf coils, medium and long waves, ideal for midget T.R.F. receivers, 11/- per pair; Midget 2-gang 0.0005mfd variable condensers, fitted slow motion drive, 12/6; Midget receiver chassis, drilled for four valves, 10½×6×2in, grey, first class, heavy quality, 9/6; Midget speaker transformers, 7/6; standard speaker transformers (Pen output), 9/-; superior quality smoothing chokes, heavy duty, 120ma, 200 ohms, 15/6; 80ma, 500 ohms, 12/6; midget smoothing chokes, 3500ma, 7/6; Midget knobs, highly polished, black, midget knobs, brown and standard knobs, ¼in diameter, at 9d. each, 8/- doz; Midget rotary switch, s.p.d.t., 3/6; push back connecting wire, 3d. yard; dials, three wavebands, short, medium and long, station names, etc., in colours, ivorine, 7×4in, 1/6; special prices for quantities; replacement find coils, for standard 8in m.e. speakers, 400 ohms, also useful as smoothing choke winding, 5/-, 48/- doz; universal mains droppers for all receivers, 1,000 ohms, 0.2 amp, fitted two variable taps, 4/6; 750 ohms, 0.3 amp, do. taps, 5/6; heavy quality dropper, porcelain former, do. taps, fixing feet, superior job, 950 ohms, 0.2 amp, and 800 ohms, 0.3 amp, 7/6 each; mains transformers, 350-350, 4v, 2 amp, 4v 4 amp, standard prim., and ditto, 6.3v 5.0v l.t., at 35/- each, superior class job; wire-wound potentiometers, 2,000 ohms, 6/6; condensers, tubular wire ends, 350v working, 0.1 and 0.01 mfd, 7/6 doz; Paxolin chassis mounting valveholders, British and American, 9d. each, 8/- doz; screened braided single core cable, 1/- yard; 2-way screened leads, braided insulation, 54in, fully finished, terminating four plugs, for mike, gramo, amplifiers, etc., 3/-; superior quality line cord, 50 ohms per foot, 3-way, 0.3 amp, 6/- yard; everything for the serviceman and experimenter, full range speakers, sleeving, etc., etc.; send for lists; licence to export to N. Ireland; stamped addressed envelope with all enquiries, please; postage on all orders.—O. Greenlick, 34, Bancroft Rd., Cambridge Heath Rd., London, E.1. Stepney Green 1334. [2377]

Wanted

NEW boxed valves wanted, any quantity, dealers' and service men's complete stocks bought.—J. Bull and Sons, 246, High St., Harlesden, N.W.10. [2155]

WANTED, radio valve (new), type 3Q5, preferably a G.T. (miniature) size.—Box O., Stuart Hirst, Ltd., Advertising Agents, 15, Bond St., Leeds, 1. [2384]

REPAIRS AND SERVICE

MIDWEST, McMurdo, Belmont, Crosley, M. Ferguson, etc., valves; the American experts.—Bennett's, 4, Humberstone Drive, Leicester. [2388]

METROPOLITAN RADIO SERVICE CO. guaranteed repairs to American and British receivers — 1021, Finchley Rd., N.W.11. Spe. 3000. [9641]

"SERVICE with a Smile."—Repairers of all types of British and American receivers; coil rewinds; American valves, spares, line cords.—F.R.L. Ltd., 22, Howland St., W.1. Museum 5675. [1575]

MAINS transformers service, repairs, rewinds, or construction to specification of any type, competitive prices and prompt service.—Sturdy Electric Co., Ltd., Dipton, Newcastle-upon-Tyne. [9651]

DEGALLIER'S, Ltd.—"Service with a guarantee." If you cannot get your receiver serviced, let American specialists do the job; first-class workmanship only; specialising in Air-King, Belmont, Challenger, Delco, Detroit, deWald, Emerson, Ferguson, Garod, Halli-crafter, Hammerlund, Lafayette, Meisner, McMurdo, Midwest, Majestic, Pilot, Philco, Flayer, Sparton, Stronberg-Carlson, Wells-Gardner, etc., also any British set; remember for 14 years we have handled as distributors American receivers; this is self-explanatory; s.a.e with all enquiries.—Degallier's, Ltd., 9, Westbourne Court, London, W.2. [2395]

"UNIVERSAL CIRCUITS"

by R. S. Roberts, M.Brit.I.R.E., A.M.I.R.E.
Three folders and a thirty-six page booklet, presenting the main principles of radio circuit operation in a concise and convenient form for the pocket.

- I. The Transmitter.
- II. The T.R.F. Receiver.
- III. The Superheterodyne Receiver

By means of hinged flaps, the charts give a large number of recognised alternatives for each stage. To assist the student in memorising and understanding these, a logical five-colour scheme has been adopted throughout.

"Grid Leak" says: "The Charts and Notes are really intended for students and teachers of radio, but are extremely useful to every radio engineer."

Price complete 6/3 post free, from

The Bookstall
NORTHERN POLYTECHNIC
HOLLOWAY, LONDON, N.7

HILL & CHURCHILL

BOOKSELLERS

SWANAGE DORSET

ENGLISH & AMERICAN
BOOKS IN STOCK ON

RADIO AND
TELECOMMUNICATION

CATALOGUE ON APPLICATION

Cabinets ?

Increased production facilities enable us to give immediate attention to orders for urgent requirements and we are now in a position to accept further contracts or sub-contracts for Government work.

We specialise in **AMPLIFIER and EXTENSION SPEAKER CABINETS.**

All enquiries should be accompanied by Priority No.

HIRSH & HYAMS, LTD.

Cabinet Manufacturers,
93, Hackney Road, London, E.2. Bish. 4012.

AFTER THE WAR!

The advance in Radio Technique after the war will offer unlimited opportunities of high pay and secure posts for those Radio Engineers who have had the foresight to become technically qualified. How you can do this quickly and easily in your spare time is fully explained in our unique handbook.

Full details are given of A.M.I.E.E., A.M.Brit.I.R.E., City & Guilds Exams., and particulars of up-to-date courses in Wireless Engineering, Radio Servicing, Short Waves, Television, Mathematics, etc., etc.

We Guarantee "NO PASS—NO FEE"

Prepare for to-morrow's opportunities and post-war competition by sending for your copy of this very informative 112-page guide NOW—FREE.

BRITISH INSTITUTE OF ENGINEERING TECHNOLOGY (Dept. 388)
Stratford Place, London, W.1

LASKY'S RADIO 370 HARROW RD. PADDINGTON, W.9

(Opp. Padd. Hospital). Phone: Cramingham 1979

Offer for Sale the following components:—

CONDENSERS

- 2 mfd. 600 v. Block Paper Cond. ... 2/6 each
- 4 mfd. 600 v. 4/6 each
- 800 v. 3/6 each

TUBULAR .02 mfd. 2,000 v., 1/- .25 mfd. 2,000 v., 1/6 each. .25 mfd. 350 v., 1/3 each. .05 mfd. 500 v., 1/- each. .01 mfd., 500 v., 9d. each. 50 mfd. 12 v., 1/4 each. 10 mfd. 25 v., 1/6 each. 1 mfd. 350 v., 6d. each. 2 & 3 amp. Mains Droppers, tapped, 7/6.

SPECIAL BARGAINS FOR SET BUILDERS

Grey cellulosed steel radio chassis complete with IF and aerial coils, trimmers, condensers, A and Earth sockets, 8-valve holders, resistors, and many various components, etc., etc. Size 8in. x 12in. x 1½in. Special offer 23/6. Postage Free.

- U.S.A. Octal Valve Holders ... 7/6 doz.
- Assorted Volume Cont. less switch 2/9 each
- Assorted Volume Cont. ¼, ½ and 1 meg. with switch ... 5/9 each
- Midget v.c. ½ meg, less switch ... 3/9 each
- 3 amp 3-way, line Cord, 60 ohms, per foot at 5/9 yard

VALVES! VALVES! VALVES!

We have over 5,000 new and boxed English and U.S.A. Mains and Battery Valves in stock, including 6A7, 6A8, 25A4, 75, 5Z4, U50, 35Z5, 50L6, 35L6, 6F6, FC13c, VP2, SP4, PX4, 6EN4, AC2PENDD, TDD4, U05, 6K7, 6K8, IV4/350, U12, 12A8, 12Q7, PEN36c, etc., etc.

- Rola P.M. less Transformers, 5in. at 19/6, 6½in., 21/-, 8in. at 23/6.
- Goodman's 3½in. 12 ohms V/coil at 27/6, 5in. 21/6, 10in. £2 5s., less Trans.
- Universal Speaker Transformers ... 7/6 each
- Pentode 6/6 each

Midget Spkr. Trans. shrouded 5/9 each

Send us your requirements. C.O.D. BUT CASH WITH ORDER PREFERRED.

See our Classified Adverts. under Components, p. 28 and Valves, p. 29.

Ready for Peace time ?

When you get "on the air" again, will you be able to read the speedy, well spaced messages sent by your friends who are now expert W/T Operators in the Services ?

There is nothing more annoying to a good operator than to have to read slowly sent and badly spaced morse code messages ; many of them are not even patient enough to try to read them.

Why not make sure that your Receiving is at least in the 20 w.p.m. (or more) class, and your sending accurate, well spaced and not below that speed ?

LET THE CANDLER SYSTEM TRAIN YOU Numerous Candler students are W/T Operators in the Services and many of them are readers of the "Wireless World."

LEARN MORSE CODE THE CANDLER WAY

There are Courses for Beginners as well as for Operators who wish to increase their w.p.m. speeds and improve their technique.

SEND FOR THE CANDLER "BOOK OF FACTS"

It is sent post free, and, to request a copy does not place you under the slightest obligation. Write to:—

CANDLER SYSTEM CO.
(Room 55), 121 Kingsway, London, W.C.2
Candler System Co., Denver, Colorado, U.S.A.



VOIGT For high quality loud speakers when the good times come again.
The Courts, Silverdale, London S.E.26. Phone: SYD 6666.



W. BRYAN SAVAGE
LTD.
Expert assistance in the solution of problems relating to
● TRANSFORMERS, CHOKES
● AMPLIFIERS
● POWER UNITS
and Specialised Equipment embodying
ELECTRONIC CONTROL
WESTMORELAND RD., N.W.9
COLINDALE 7131

REWINDS to mains and output transformers, field coils and chokes; prompt delivery on priority contracts.—Metropolitan Radios Service Co. 1021, Finchley Rd., N.W.11. Speedwell 3000. [2402]

MISCELLANEOUS
NEW aerial substitute invention for sale, cheap.—Eshelby, 37, Milford St., Cardiff. [2370]

FOR sale, one Douglas winding machine No. 2, complete with a.c. motor, countershaft and paper interleaver.—Box 3023. [2332]

RECONDITIONED sectional timber buildings for sale, all sizes.—D. McMaster and Co., Bures, Suffolk. Tel Bures 251. [2338]

BUILD your own pocket radio, etc.—Complete midget valve units, comprising HiVac XL and XP triodes, in holder, 2V. fil., 15/-.—P. West, 13, Lower Park, Putney Hill, S.W.15. [2365]

RUBBER stamps made up to your special requirements, and design, typical example, stamp showing name, address and profession; 9/6 post free.—V.E.S., Radio House, Ruislip. [1884]

HIGH frequency Eddy current generator, 3 to 5kw, new or second-hand, required for high vacuum laboratory.—Please send particulars to Box WW/P, c/o "Scientific," Cliffords Inn, London, E.C.4. [2350]

NIFE nickel cadmium alkaline batteries.—Quantity alkaline cells, 70 ah to 300 ah capacity, types L, S and T, suitable for lighting plants, traction, starter batteries, etc.; also 1,500 yards multi circuit cable, consisting of 14 separate rubber insulated l.c.c. conductors, each 1/0.36in. whole compounded, t.r. insulated and braided; write for list; trade supplied.—Mathew Bros., 25, Sandy Lane North, Wallington, Tel. 4050. [2319]

NO set!! Make the Victory Four (4-valve universal mains medium-wave receiver) yourself at home; 5/- brings you theoretical circuit, extremely clear wiring diagrams, component layout, and precise point-to-point wiring instructions, together with list of components, which in many cases you will have in discarded sets, or are easily obtained from usual dealer; really good performance a certainty, and in addition we will answer your queries free or charge if accompanied by s.a.e.; terms, cash with order; no callers; send stamped addressed envelope for list of parts, etc., available.—Franklin Developments, Weldon, The Avenue, Finchley, London, N.3. [2376]

SITUATIONS VACANT
SERVICE manager for valve deaf aids, permanent prospective post for radio man with sound knowledge i.f. amplification, able to control staff and attend to correspondence; scheduled occupation.—Write age, experience, salary required, Box 3022. [2329]

DESIGNER required in Slough area with electrical and mechanical experience in connection with design and installation of radio apparatus; workshop and drawing office experience essential; salary £350 to £450, according to qualifications; ruling Civil Service war bonus also paid, together with quarterly gratuity in certain circumstances in respect of excess hours worked.—Applications in writing (no personal calls), stating age, qualifications and experience, name and address of present employer, and quoting Order No. 305 (Reading), should be addressed to Ministry of Labour and National Service, Appointments Department, Sardinia St., Kingsway, London, W.C.2. [2373]

SITUATIONS WANTED
COMMUNICATIONS engineer requires administrative post, 12 years' experience of design, development and precision of transmitters, receivers and precision measuring equipment, fully conversant with the requirements of Government departments; refs. well known in the industry.—Box 5026. [2342]

TECHNICAL TRAINING
GREAT possibilities exist for technically qualified engineers, key men in wartime and afterwards. Through the home-study courses of The T.I.G.B. take a recognised engineering qualification, such as A.M.I.Mech.E., A.M.I.E.E., A.F.R.Ae.S., A.M.I.Chem.E., C. and G., etc., in which examinations the T.I.G.B. students have gained 25 FIRST PLACES and hundreds of passes. Write today for 'The Engineer's Guide to Success'—free—containing the world's widest choice of engineering courses covering all branches, including aeronautical, mechanical, electrical, wireless, chemical, etc.

THE TECHNOLOGICAL INSTITUTE OF GREAT BRITAIN, 82, Temple Bar House, London, E.C.4. [1403]

TUITION
LEARN Morse code the Candler way.—See advertisement on this page. [1292]
RADIO training.—P.M.G. exams, and I.E.E. Diploma; prospectus free.—Technical College, Hull. [0611]

VALVES

This is part of our current stock of valves and if all their equivalents were mentioned it would be found that we can supply either the exact valve or a suitable replacement for almost any type. Wherever possible please order C.O.D. Stamp with enquiries, please.

PRICES STRICTLY B.O.T. RETAIL.

BATTERY—210HL, LD210, 5/10; LP2, P220, PM2A, 7/4; HD24, TDD2A, 9/3; 210SPT, 210VPT, 215SG, 220EPT, 220VOT, SP210, KT2, KT24, PM12M, PM22A, SP2, 8215VM, VP2, VP2B, X22, W21, Z21, Z22, 11/-; 230XP, 12/3; X24, 12/10. A/C TYPES.—2D4A, 6/9; 904V, AC2HL, MH4, MH14, 9/2; AZ1, AZ31, DW2, DW4-500, IW4-350, 11/-; AC044, MH41, PX4, TDD4, 11/7; AC/VP1, AC/VP2, AC/VP, AC/CPen, MVSPen, MVSPenB, Pen4, Pen4VA, SP24, VP4B, VP74, 12/10; AC/PT1, FC4, MX40, TH4, TX41, VHT4, 41MPG, 14/-; PenB4, 14/8; Pen4DD, 15/3; MP/Pen, 16/6; PW4-500, 18/3; PX25, PP5/400, 24/4; Pen28, 30/5.

UNIVERSAL—2D18A, 9/2; CY1, U31, URIC, UR3C, 11/-; 11D3, TDD13C, 11/7; SD2, 9D2, 13SP4, CL4, CL33, Pen38C, SP12, SP1320, VP13A, VP13C, 12/10; PenDD4020, 15/3.

MAZDA—HL23, 5/10; U05, U06, U07, VP23, 11/-; HL41DD, HL13DD, 11/7; Pen45, SP41, TP23, VP41, 12/10; TH41, TH23, 14/-; QP25, 15/3.

E. TYPES—EM4, 11/4; EBC3, EBC33, 11/7; CL4, CL37, EP3, EL3, EL33, 12/10; ECH2, ECH3, ECH33, EP5, EP6, EK2, EL2, 14/-; EBL1, EBL31, 15/3; EL5, 16/6; EL35, 18/3.

AMERICAN—0Z4, 1A5, 1A6, 1A7, 1B5, 1C5, 1H5, 1H6, 2A6, 2A7, 5U4, 5Y3, 5Z4, 6A3, 6A4, 6A6, 6AG6, 6A7 conversion, 6C6, 6D6, 6C8, 6E6, 6F5, 6F6, 6F8, 6H6, 6G6, 6J7, 6K6, 6K7, 6K8, 6L6, 6L7, 6P5, 6Q7, 6S07, 6S7, 6V6, 6X5, 6Z5, 10, 12A5, 12Q7, 12SA7, 12SP5, 12Z5, 15, 19, 24, 25, 25A7, 25D3, 25Y5 conversion, 25Z5 conversion 25Z6, 32, 33, 34, 35, 37, 38, 46, 48, 49, 50, 53, 57, 71A, 75, 76, 78, 79, 80, 81, 85, 89, 185B3 (Ballast), K55B and C (Ballast).

VALVES & ADAPTORS

In the few cases where we cannot supply the exact valve or equivalent we can get your set going with a valve and an adaptor, the additional cost being 4/6.

SPARES

LINE CORD—3 amp, 3 core 60 ohms, per ft., extremely good quality, 6/9 per yd. **CELLULOSE CEMENT** for speaker, valve and most other repairs, 5/- large tin. "SERVISOL," more than a switch cleaner, 5/- tin. **MAINS TRANSFORMERS**, 350-375, 4-volt heaters, 29/3; **VOLUME CONTROLS**, with switch, 7/6; **VALVE EQUIVALENTS CHARTS**, 1/7, post free.

J. BULL & SONS

246, HIGH ST., HARLESDEN, N.W.10.

NEW and Second-hand Radio Parts and Valves, for students, experimenters, constructors, etc. Components. Large assortment, £1 per parcel. Valves. 6 assorted battery types, £1. 4 assorted Mains types, £1. Resistors. 30 assorted 1/2 watt, 10/- 20 assorted 1 watt, 10/- 10 assorted 2 watt and larger, 10/- Fixed Condensers. 20 assorted wire ended, 10/- 30 assorted tag ended, 10/- 15 assorted Philco (High volts test), block type, 10/- Aerial Coils. Dual range Philco. Medium and low waves, 5/- Ditto, with self-contained trimmers, 7/- Philco Car Aerials. Complete boxed, with all fittings, screened cable, instructions, etc. Pre-war price, 12/6. Exceptional Value. Satisfaction Guaranteed.

Terms.—Cash with order, postage extra. Stamp with all enquiries please.

E. H. ROBINS TRADING CO., LTD.
44 KYLE ORESCENT SOUTH, WHITECHURCH, GLAM.

WARD ROTARY CONVERTERS

Petrol Electric Generating Plants, H.T. Generators, D.C. Motors, Frequency Changers, etc., up to 25 K.V.A.

CHAS. F. WARD
37, WHITE POST LANE, HACKNEY WICK, E.9
Phone: Amherst 1393

COACHING for P.M.G. examinations; 150 typical 1st and 2nd class technical questions, price by post 5/-. The North Eastern School of Wireless, 69, Osborne Rd., Newcastle-upon-Tyne, 2. [2081]

RADIO Engineering.—Television and Wireless Telegraphy, comprehensive postal courses of instruction. Apply British School of Telegraphy, Ltd., 179, Clapham Rd., London, S.W.9 (Estd. 1906). Also instruction at school in wireless for H.M. Merchant Navy and R.A.F. [9249]

A POSTAL training in electrical engineering—power or radio; individual correspondence tuition by highly qualified engineers with wide teaching and technical experience. Elementary or advanced courses. Preparation for recognised examinations. Pre-service training specially arranged.—G. B., 18, Springfield Mount, Kingsbury, N.W.9. [1731]

"ENGINEERING Opportunities," free 112-page guide to training for A.M.I. Mech.E., A.M.I.E.E., and all branches of engineering and building; full of advice for expert or novice; write for free copy, and make your peacetime future secure.—B.I.E.T. (Dept. 387B), 17, Stratford Place, London, W.1. [2333]

MATRICULATION

brings Success & Security

Whatever your age, you can now study for the all-important Matriculation Examination at home on "NO PASS—NO FEE" terms. "MATRIC" is the accepted passport to all careers, and opens up opportunities which would otherwise be completely closed to you. Ensure the success and security of you and yours through post-war difficulties by writing for our valuable "Guide to Matriculation" immediately — FREE.

B.T.I. (Dept. 114)

356, Oxford Street, London, W.1.

SPEAKER REPAIRS by Specialists

Any make, British or American

Best Service Moderate Charges

TRADE ONLY
Also Components for Service Men at keenest prices. List 1d. Holders of Export Licence for Northern Ireland.

A. W. F. RADIO PRODUCTS 'Phone: 11926
13, Lilycroft Road, Bradford, Yorks.

BATTERY CHARGERS & TRICKLE CHARGERS



for all purposes
"QUIK-CHARGE" CHARGERS
well known for reliability
Booklet R.15, giving useful information and describing 12 Models, on request
RUNBAKEN-MANCHESTER

CERAMIC PARTS METALLISED AND TINNED

E. & M. DEVELOPMENTS LTD.
492, IPSWICH ROAD, SLOUGH, BUCKS.
Tel.: SLOUGH 21435.

Radio Service

REWINDS. Mains from 25/-. Output from 6/-. Field Coils, 9/-. PROMPT DELIVERY.
VALVES (B.V.A.) Send for list—good selec.
PHILIPS D.C. CONVERTERS—Bought—Sold—and Exchanged.
S.A.E. to—

A.D.S. CO. 261/3/5, Lichfield Road, ASTON, BIRMINGHAM, 6.

THE Tuitionary Board of the Institute of the Practical Radio Engineers have available home study courses covering elementary, theoretical, mathematical, practical, and laboratory tuition in radio and television engineering; the text is suitable coaching matter for I.P.R.E. Service-entry and progressive exams; tuition fees—at pre-war rates—are moderate.—The Syllabus of Instructional Text may be obtained post free from the Secretary, Bush House, Walton Avenue, Henley-on-Thames, Oxon. [1462]

PATENT NOTICES

THE proprietors of British Patent No. 513650, entitled "Improvements in closures for evacuated envelopes" offer same for license or otherwise to ensure its practical working in Great Britain.—Inquiries to Singer, Ehlert, Stern and Carlberg, Chrysler Building, New York City 17, N.Y., U.S.A. [2327]

THE proprietor of British Patents Nos. 527353 and 527484 entitled "Improvements in photoelectric cells, and methods and means for making, sensitising, and stabilising the same" and "Improvements in photoelectric cells, and method for making, sensitising and stabilising the same," respectively, offers same for license or otherwise to ensure practical working in Great Britain.—Inquiries to Singer, Ehlert, Stern and Carlberg, Steger Building, Chicago 4, Illinois, U.S.A. [2331]

BOOKS, INSTRUCTIONS, ETC.

WEBB'S radio map of the world locates any station heard, size 40x50in., 4/6, post 6d., on linen, 10/6, post free.—Webb's Radio, 14, Soho St., London, W.1. Tel. Gerard 2089. [9947]

Wanted

WANTED. "Wireless Engineer," Sept. and Oct., 1943.—Johnston, 31, Wilmington Way, Brighton. [2340]

WANTED. Rider Manuals, I-XI, any service sheets, in good condition; good price.—Box 3028. [2352]

"SYSTEMATIC RADIO SERVICING"

A method for organising the repair-shop, devised and employed by J. Bull. Also a catalogue of many Radio Service Aids including "History of Faults," "Job Cards," which almost repair the sets, "Valve Base Data Cards," and perhaps most important, a Rectifier which will replace any of the popular Universal valves such as 1Z3, 2Z5, 1D5, U30, 405UA, etc. Price 1/7 p.f.
V.E.S.,

(W) Radio House, Melthorne Drive, Ruislip, Mdx.

Varley

TRANSFORMERS and CHOKES
For RELIABILITY

SEND US YOUR ENQUIRIES

OLIVER PELL CONTROL LTD
CAMBRIDGE ROW, BURRAGE ROAD, WOOLWICH, LONDON.S.E.

Remember-Walter

J. & H. LTD

RADIO RADIO RADIO
STAMPINGS • CHASSIS • PRESSINGS

FARM LANE, FULHAM, S.W.6. TELEPHONE: FULHAM 5234

C.R.C.4

INVENTORS

The world-wide Simmonds Organisation has established new methods and new products in many industries with great success. Simmonds Development Corporation seeks new ideas and inventions of brilliance and ingenuity to be developed by the technical resources and marketing knowledge of the Simmonds Group.

ALL COMMUNICATIONS MUST BE IN WRITING IN FIRST INSTANCE TO—

The SIMMONDS GROUP

LONDON
MELBOURNE
PARIS • NEW YORK
LOS ANGELES

SIMMONDS DEVELOPMENT CORPORATION LTD. 2-3 NORFOLK ST. W.C.2

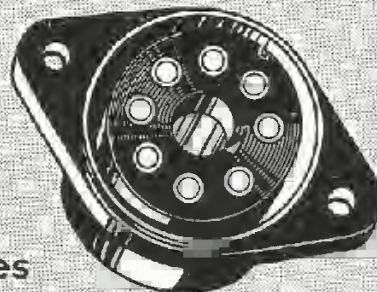
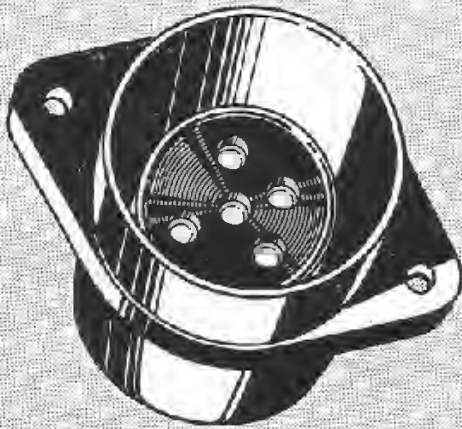
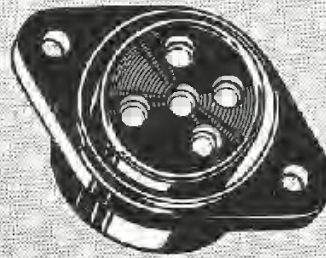
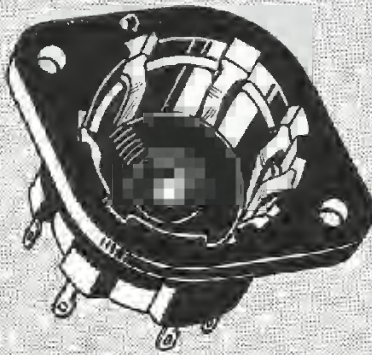
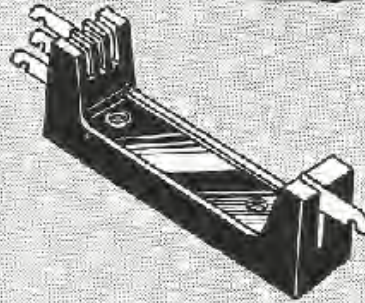
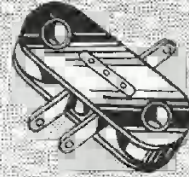
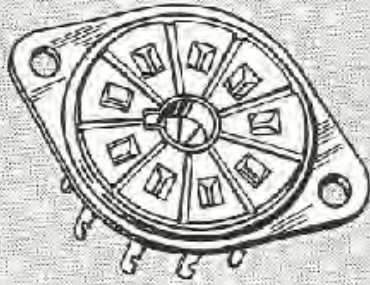

BELLING & LEE LTD
CAMBRIDGE ARTERIAL ROAD, ENFIELD, MIDDX

GA 8790

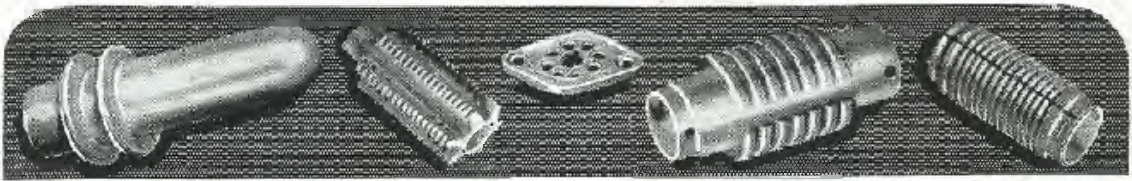

Clear as a Crystal

AND HERE IS THE REASON..

• • • the answer has been found in Bullers Low Loss Ceramics to the problem of Dielectric Loss in High Frequency circuits.

Years of laboratory research and development have brought these materials to a high degree of efficiency. To-day they are in constant use for transmission and reception, and play a vital part in maintaining communications under all conditions.

Made in Three Principal Materials

FREQUELEX—An Insulating material of Low Dielectric Loss, for Coil Formers, Aerial Insulators, Valve Holders, etc.

PERMALEX—A High Permittivity Material. For the construction of Condensers of the smallest possible dimensions.

TEMPLEX—A Condenser material of medium permittivity. For the construction of Condensers having a constant capacity at all temperatures.



Bullers

LOW LOSS CERAMICS

BULLERS, LTD., THE HALL, OATLANDS DRIVE, WEYBRIDGE, SURREY
 Telephone : Walton-on-Thames 2451. Manchester Office : 196, Deansgate, Manchester

